

Volume 3

CONFIGURATION AND ADVANCED OPERATION

Contents of Volume 3

Figures of Volume 3.....vii

About Our Company..... ix

Contacting Our Corporate Headquarters ix

 Getting User Support ix

About the Flow Computer Applications x

About the User Manual..... x

 Target Audience x

 Manual Structure xi

 Volume 1. System Architecture and Installation xi

 Volume 2. Basic Operation xi

 Volume 3. Configuration and Advanced Operation xi

 Volume 4. Modbus™ Database Addresses and Index Numbersxii

 Volume 5. Technical Bulletins.....xii

 Conventions Used in this Manualxii

 Trademark Referencesxiii

 Copyright Information and Modifications Policyxiv

Warranty, Licenses and Product Registration..... xiv

1. Overview of Firmware Revisions 22.74/26.74	1-1
1.1. Number of Meter Runs - Type of Flowmeters.....	1-1
1.2. Product Configuration	1-2
1.3. Configurable Sensors per Meter Run.....	1-2
1.4. Configurable Sensors per Prover	1-2
1.5. Temperature	1-2
1.6. Densitometers	1-2
1.7. Station Capability.....	1-2
1.8. Auxiliary Inputs	1-2
1.9. Number of products - Information Stored/Product.....	1-2
1.10. Type of Products Measured	1-3
1.11. Batching and Interface Detection	1-3
1.12. Auto Proving Features.....	1-3
1.13. Retroactive Meter Factors and Override Gravity	1-3
1.14. Retroactive Density Correction Factor	1-3
1.15. Meter Factor Linearizing Curves	1-4
1.16. PID Control Functions	1-4
1.17. Flow Weighted Averages	1-4
1.18. User-Programmable Digital I/O	1-4
1.19. User-Programmable Logic Functions	1-4
1.20. User-Programmable Alarm Functions	1-4
1.21. User-Programmable Variables.....	1-4
1.22. User Display Setups	1-5
1.23. User Report Templates.....	1-5
1.24. Serial Communication Links.....	1-5
1.25. Peer-to-Peer Communications.....	1-5
1.26. Archive Data	1-5
1.27. OmniCom™ Windows Version Software Communications Package	1-5
1.28. OmniView™ Windows Version Interface Software Package	1-5
1.29. Ethernet Module.....	1-6

2. Flow Computer Configuration	2-1
2.1. Introduction	2-1
2.2. Configuring with the Keypad in Program Mode	2-1
2.2.1. Entering the Program Mode	2-1
2.2.2. Changing Data	2-1
2.2.3. Menu Selection Method	2-2
2.2.4. Random Access Method	2-2
2.2.5. Passwords	2-3
2.3. Getting Help	2-4
2.4. Program Inhibit Switch	2-4
2.5. Configuring the Physical Inputs / Outputs	2-5
2.5.1. Miscellaneous Configuration (Misc. Setup Menu)	2-5
2.5.2. Physical I/O Points not Available for Configuration	2-6
2.5.3. Password Maintenance Settings	2-6
2.5.4. Entries Requiring a Valid Privileged Password	2-7
2.5.5. Module Settings	2-8
2.5.6. Meter Station Settings	2-8
2.5.7. Meter Run Settings	2-11
2.5.8. Prover Settings	2-13
2.5.9. PID Control Settings	2-14
2.5.10. Analog Output Settings	2-15
2.5.11. Front Panel Counter Settings	2-16
2.5.12. Programmable Boolean Statements	2-17
2.5.13. Programmable Variable Statements	2-19
2.5.14. User Display Settings	2-21
2.5.15. Digital I/O Point Settings	2-23
2.5.16. Serial Input / Output Settings	2-25
2.5.17. Custom Modbus™ Data Packet Settings	2-27
2.5.18. Programmable Logic Controller Setup	2-27
2.5.19. Archive File Setup	2-28
2.5.20. Peer-to-Peer Communications Settings	2-28
2.6. Setting Up the Time and Date	2-33
2.6.1. Accessing the Time/Date Setup Submenu	2-33
2.6.2. Time and Date Settings	2-33
2.7. Configuring the Meter Station	2-34
2.7.1. Accessing the Station Setup Submenu	2-34

2.7.2. Meter Station Settings2-34

2.8. Configuring Meter Runs 2-37

2.8.1. Accessing the Meter Run Setup Submenu2-37

2.8.2. Meter Run Settings2-37

2.9. Configuring Temperature 2-40

2.9.1. Accessing the Temperature Setup Submenu.....2-40

2.9.2. Station and Meter Run Temperature Settings.....2-40

2.9.3. Station and Meter Run Density Temperature Settings.....2-41

2.9.4. Prover Temperature Settings2-42

2.9.5. Prover Density Temperature Settings2-43

2.10. Configuring Pressure 2-44

2.10.1. Accessing the Pressure Setup Submenu.....2-44

2.10.2. Station and Meter Run Pressure Settings2-44

2.10.3. Station and Meter Run Density Pressure Settings2-45

2.10.4. Prover Pressure Settings.....2-46

2.10.5. Prover Density Pressure Settings.....2-47

2.11. Configuring Meter Relative Density / API Relative Density..... 2-48

2.11.1. Accessing the Gravity/Density Setup Submenu.....2-48

2.11.2. Meter Relative Density / Density Settings2-48

2.12. Configuring PID Control Outputs 2-51

2.12.1. Accessing the PID Control Setup Submenu.....2-51

2.12.2. PID Control Output Settings2-51

2.13. Configuring Provers 2-53

2.13.1. Accessing the Prover Setup Submenu.....2-53

2.13.2. Prover Settings2-53

2.14. Configuring Products 2-57

2.14.1. Accessing the Product Setup Submenu.....2-57

2.14.2. Product Settings2-57

2.15. Configuring Batches..... 2-67

2.15.1. Batch Preset Setup.....2-67

2.16. Configuring Miscellaneous Factors 2-68

2.16.1. Accessing the Factor Setup Submenu2-68

2.16.2. Factor Settings.....2-68

2.17. Configuring Printers 2-69

2.17.1. Accessing the Printer Setup Submenu.....2-69

2.17.2. Printer Settings2-69

3. User-Programmable Functions	3-1
3.1. Introduction	3-1
3.2. User-Programmable Boolean Flags and Statements.....	3-1
3.2.1. What is a Boolean?.....	3-1
3.2.2. Sign (+, -) of Analog or Calculated Variables (5001 → 8999)	3-3
3.2.3. Boolean Statements and Functions	3-3
3.2.4. How the Digital I/O Assignments are Configured	3-8
3.3. User Programmable Variables and Statements	3-10
3.3.1. Variable Statements and Mathematical Operators Allowed.....	3-10
3.3.2. Using Boolean Variables in Variable Statements.....	3-12
3.3.3. Entering Values Directly into the User Variables.....	3-13
3.3.4. Using the Variable Expression as a Prompt.....	3-13
3.3.5. Password Level Needed to Change the Value of a User Variable	3-13
3.3.6. Using Variables in Boolean Expressions.....	3-14
3.4. User Configurable Display Screens	3-15
4. Flow Equations and Algorithms for US Customary Units (Revision 22.74+)	4-1
4.1. Liquid Flow Rate for Flowmeters.....	4-1
4.1.1. Volumetric Flow Rate at Flowing Conditions 'Q _v ' (Bbls/hr)	4-1
4.1.2. Volumetric Flow Rate at Base Conditions 'Q _b ' (Bbls/hr).....	4-1
4.1.3. Mass Flow Rate 'Q _m ' (KLbs/hr).....	4-1
4.1.4. Nomenclature	4-2
4.2. Correction Factors for Liquid Flow	4-3
4.2.1. Meter Factor in Use 'M _F '	4-3
4.2.2. Volume Correction Factor 'V _{CF} '	4-4
4.2.3. Correction Factor for Pressure on Liquid 'C _{PL} '	4-5
4.2.4. Correction Factor for Sediment and Water Content 'C _{S&W} '	4-5
4.3. Densities and Other Properties of Liquids	4-6
4.3.1. Flowing Density 'ρ' for Crude Oil and Refined Products.....	4-6
4.3.2. Density and Relative Density (Specific Gravity) Calculated from Live Digital Densitometer Output Frequency	4-7
4.4. Recalculation of Batch Ticket	4-11
4.4.1. Recalculated Gross Standard Volume 'GSV _{Recalc} ' (Bbls)	4-11
4.4.2. Recalculated Net Standard Volume	4-11
4.4.3. Factored Gross Volume 'FGV' (Bbls)	4-12
4.4.4. Net Weight Delivered 'NWD'	4-12

4.5. Liquid Flow Rate for Provers	4-13
4.5.1. Prove Gross Flow Rate at Flowing Conditions (Bbls/hr)	4-13
4.5.2. Prove Flow Rate using Pulse Interpolation Method	4-13
4.5.3. Nomenclature	4-14
4.5.4. Meter Factors for Provers.....	4-15
4.6. Calculations for PID Control	4-18
4.6.1. Primary Variable Error % 'e _p '	4-18
4.6.2. Secondary Variable Error % 'e _s '	4-18
4.6.3. Control Output % 'C ₀ ' (Before Startup Limit Function)	4-18
4.6.4. Integral Error 'Σe'.....	4-19
5. Flow Equations and Algorithms for SI (Metric) Units (Revision 26.74+)	5-1
5.1. Liquid Flow Rate for Flowmeters	5-1
5.1.1. Volumetric Flow Rate at Flowing Conditions 'Q _v ' (m ³ /hr)	5-1
5.1.2. Volumetric Flow Rate at Base Conditions 'Q _b ' (m ³ /hr)	5-1
5.1.3. Mass Flow Rate 'Q _m ' (Ton/hr).....	5-1
5.1.4. Nomenclature	5-2
5.2. Correction Factors for Liquid Flow	5-3
5.2.1. Meter Factor in Use 'M _F '	5-3
5.2.2. Volume Correction Factor 'V _{CF} '	5-4
5.2.3. Correction Factor for Pressure on Liquid 'C _{PL} '	5-5
5.3. Densities and Other Properties of Liquids	5-6
5.3.1. Flowing Density 'ρ' for Crude Oil and Refined Products.....	5-6
5.3.2. Density of Ethane, Propane and C3+ Mixes	5-6
5.3.3. Density and Relative Density (Specific Gravity) Calculated from Live Digital Densitometer Output Frequency	5-7
5.4. Liquid Flow Rate for Provers	5-11
5.4.1. Prove Gross Flow Rate at Flowing Conditions (m ³ /hr).....	5-11
5.4.2. Nomenclature	5-11
5.4.3. Meter Factors for Provers.....	5-12
5.5. Calculations for PID Control	5-15
5.5.1. Primary Variable Error % 'e _p '	5-15
5.5.2. Secondary Variable Error % 'e _s '	5-15
5.5.3. Control Output % 'C ₀ ' (Before Startup Limit Function)	5-15
5.5.4. Integral Error 'Σe'.....	5-16

Figures of Volume 3

Fig. 1-1. Typical Configuration Using Helical Turbine, Positive Displacement Flowmeters	1-1
Fig. 2-1. Figure Showing Program Inhibit Switch	2-4
Fig. 3-1. Figure Showing Automatic Four-Meter Flow Zone Thresholds	3-6
Fig. 3-2. Figure Showing Four-Meter Run Valve Switching	3-7
Fig. 3-3. Keypad Layout - A through Z Keys	3-16

For Your Information



About Our Company

OMNI Flow Computers, Inc. is the world's leading manufacturer and supplier of panel-mount custody transfer flow computers and controllers. Our mission is to continue to achieve higher levels of customer and user satisfaction by applying the basic company values: our people, our products and productivity.

- OMNI flow computers -**
Our products are currently being used world-wide at:
- ⊖ Offshore oil and gas production facilities
 - ⊖ Crude oil, refined products, LPG, NGL and gas transmission lines
 - ⊖ Storage, truck and marine loading/offloading terminals
 - ⊖ Refineries; petrochemical and cogeneration plants.

Our products have become the international flow computing standard. OMNI Flow Computers pursues a policy of product development and continuous improvement. As a result, our flow computers are considered the "brain" and "cash register" of liquid and gas flow metering systems.

Our staff is knowledgeable and professional. They represent the energy, intelligence and strength of our company, adding value to our products and services. With the customer and user in mind, we are committed to quality in everything we do, devoting our efforts to deliver workmanship of high caliber. Teamwork with uncompromising integrity is our lifestyle.

Contacting Our Corporate Headquarters



OMNI Flow Computers, Inc.
12620 West Airport, Suite 100
Sugar Land, Texas 77477 USA



Phone: 281-240-6161
Fax: 281-240-6162



World-wide Web Site:
<http://www.omniflow.com>



E-mail Addresses:
Helpdesk@omniflow.com

Getting User Support

Technical and sales support is available world-wide through our corporate or authorized representative offices. If you require user support, please contact the location nearest you (see insert) or our corporate offices. Our staff and representatives will enthusiastically work with you to ensure the sound operation of your flow computer.

About the Flow Computer Applications

OMNI 6000 and OMNI 3000 Flow Computers are integrable into the majority of liquid and gas flow measurement and control systems. The current firmware revisions of OMNI 6000/OMNI 3000 Flow Computers are:

- θ **20.74/24.74:** Turbine/Positive Displacement/Coriolis Liquid Flow Metering Systems with K Factor Linearization (US/metric units)
- θ **21.74/25.74:** Orifice/Differential Pressure Liquid Flow Metering Systems (US units/metric units)
- θ **22.74/26.74:** Turbine/Positive Displacement Liquid Flow Metering Systems with Meter Factor Linearization (US/metric units)
- θ **23.74/27.74:** Orifice/Turbine Gas Flow Metering Systems (US/metric units)

About the User Manual

This manual applies to .74+ firmware revisions of OMNI 6000 and OMNI 3000 Flow Computers. It is structured into 5 volumes and is the principal part of your flow computer documentation.

Target Audience

As a user's reference guide, this manual is intended for a sophisticated audience with knowledge of liquid and gas flow measurement technology. Different user levels of technical know-how are considered in this manual. You need not be an expert to operate the flow computer or use certain portions of this manual. However, some flow computer features require a certain degree of expertise and/or advanced knowledge of liquid and gas flow instrumentation and electronic measurement. In general, each volume is directed towards the following users:

- θ Volume 1. System Architecture and Installation
 - ◆ Installers
 - ◆ System/Project Managers
 - ◆ Engineers/Programmers
 - ◆ Advanced Operators
 - ◆ Operators
- θ Volume 2. Basic Operation
 - ◆ All Users
- θ Volume 3. Configuration and Advanced Operation
 - ◆ Engineers/Programmers
 - ◆ Advanced Operators
- θ Volume 4. Modbus™ Database Addresses and Index Numbers
 - ◆ Engineers/Programmers
 - ◆ Advanced Operators
- θ Volume 5. Technical Bulletins
 - ◆ Users with different levels of expertise.

Manual Structure

The User Manual comprises 5 volumes; each contained in separate binding for easy manipulation. You will find a detailed table of contents at the beginning of each volume.

Volume 1. System Architecture and Installation

Volume 1 is generic to all applications and considers both US and metric units. This volume describes:

- θ Basic hardware/software features
- θ Installation practices
- θ Calibration procedures
- θ Flow computer specifications

Volume 2. Basic Operation

This volume is generic to all applications and considers both US and metric units. It covers the essential and routine tasks and procedures that may be performed by the flow computer operator. Both US and metric units are considered.

General computer-related features are described, such as:

- θ Overview of keypad functions
- θ Adjusting the display
- θ Clearing and viewing alarms
- θ Computer totalizing
- θ Printing and customizing reports

The application-related topics may include:

- θ Batching operations
- θ Proving functions
- θ PID control functions
- θ Audit trail
- θ Other application specific functions

Depending on your application, some of these topics may not be included in your specific documentation. An index of display variables and corresponding key press sequences that are specific to your application are listed at the end of each version of this volume.

Volume 3. Configuration and Advanced Operation

Volume 3 is intended for the advanced user. It refers to application specific topics and is available in four separate versions (one for each application revision). This volume covers:

- θ Application overview
- θ Flow computer configuration data entry
- θ User-programmable functions
- θ Modbus™ Protocol implementation
- θ Flow equations and algorithms

User Reference Documentation - The User Manual is structured into five volumes. Volumes 1 and 5 are generic to all flow computer application revisions. Volumes 2, 3 and 4 are application specific. These have four versions each, published in separate documents; i.e., one per application revision per volume. You will receive the version that corresponds to your application revision. The volumes respective to each application revision are:

Revision 20/24.74:
Volume #s 2a, 3a, 4a

Revision 21/25.74:
Volume #s 2b, 3b, 4b

Revision 22/26.74:
Volume #s 2c, 3c, 4c

Revision 23/27.74:
Volume #s 2d, 3d, 4d

For example, if your flow computer application revision is 20/24.74, you will be supplied with Volumes 2a, 3a & 4a, along with Volumes 1 & 5.

Volume 4. Modbus™ Database Addresses and Index Numbers

Volume 4 is intended for the system programmer (advanced user). It comprises a descriptive list of database point assignments in numerical order, within our firmware. This volume is application specific, for which there is one version per application revision.

Volume 5. Technical Bulletins

Volume 5 includes technical bulletins that contain important complementary information about your flow computer hardware and software. Each bulletin covers a topic that may be generic to all applications or specific to a particular revision. They include product updates, theoretical descriptions, technical specifications, procedures, and other information of interest.

This is the most dynamic and current volume. Technical bulletins may be added to this volume after its publication. You can view and print these bulletins from our website.

Manual Updates and Technical Bulletins -
 Volume 5 of the User Manual is a compendium of Technical Bulletins. They contain updates to the user manual. You can view and print updates from our website:
<http://www.omniflow.com>

Typographical Conventions - These are standard graphical/text elements used to denote types of information. For your convenience, a few conventions were established in the manual's layout design. These highlight important information of interest to the reader and are easily caught by the eye.

Conventions Used in this Manual

Several typographical conventions have been established as standard reference to highlight information that may be important to the reader. These will allow you to quickly identify distinct types of information.

CONVENTION USED	DESCRIPTION
<p>Sidebar Notes / Info Tips</p> <p><u>Example:</u></p> <div style="border: 1px solid black; padding: 5px; width: fit-content;"> <p>INFO - Sidebar notes are used to highlight important information in a concise manner.</p> </div>	<p>Sidebar notes or "Info Tips" consist of concise information of interest which is enclosed in a gray-shaded box placed on the left margin of a page. These refer to topics that are either next to them, or on the same or facing page. It is highly recommended that you read them.</p>
<p>Keys / Keypress Sequences</p> <p><u>Example:</u></p> <p>[Prog] [Batch] [Meter] [n]</p>	<p>Keys on the flow computer keypad are denoted with brackets and bold face characters (e.g.: the 'up arrow' key is denoted as [↑]). The actual function of the key as it is labeled on the keypad is what appears between brackets. Keypress sequences that are executed from the flow computer keypad are expressed in a series of keys separated by a space (as shown in the example).</p>
<p>Screen Displays</p> <p><u>Example:</u></p> <div style="border: 2px solid gray; padding: 10px; width: fit-content;"> <p>Use Up/Down Arrows To Adjust Contrast; Left, Right Arrows To Adjust Backlight</p> </div>	<p>Sample screens that correspond to the flow computer display appear surrounded by a dark gray border with the text in bold face characters and mono-spaced font. The flow computer display is actually 4 lines by 20 characters. Screens that are more than 4 lines must be scrolled to reveal the text shown in the manual.</p>

CONVENTION USED	DESCRIPTION
<p>Headings</p> <p><u>Example:</u></p> <p>2. Chapter Heading</p> <p>2.3. Section Heading</p> <p>2.3.1. Subsection Heading</p>	<p>Sequential heading numbering is used to categorize topics within each volume of the User Manual. The highest heading level is a chapter, which is divided into sections, which are likewise subdivided into subsections. Among other benefits, this facilitates information organization and cross-referencing.</p>
<p>Figure Captions</p> <p><u>Example:</u></p> <p>Fig. 2-3. <i>Figure No. 3 of Chapter 2</i></p>	<p>Figure captions are numbered in sequence as they appear in each chapter. The first number identifies the chapter, followed by the sequence number and title of the illustration.</p>
<p>Page Numbers</p> <p><u>Example:</u></p> <p>2-8</p>	<p>Page numbering restarts at the beginning of every chapter and technical bulletin. Page numbers are preceded by the chapter number followed by a hyphen. Technical bulletins only indicate the page number of that bulletin. Page numbers are located on the outside margin in the footer of each page.</p>
<p>Application Revision and Effective Publication Date</p> <p><u>Examples:</u></p> <p>All.74 ♦ 06/07</p> <p>20/24.74 ♦ 06/07</p> <p>21/25.74 ♦ 06/07</p> <p>22/26.74 ♦ 06/07</p> <p>23/27.74 ♦ 06/07</p>	<p>The contents of Volume 1 and Volume 5 are common to all application revisions and are denoted as All.74. Content of Volumes 2, 3 and 4 are application specific and are identified with the application number. These identifiers are included on every page in the inside margin of the footer, opposite the page number. The publication/effective date of the manual follows the application identification. The date is expressed as month/year (e.g.: June 2007 is 06/07).</p>

Trademark References

The following are trademarks of OMNI Flow Computers, Inc.:

- o OMNI 3000
- o OMNI 6000
- o OmniCom®

Other brand, product and company names that appear in this manual are trademarks of their respective owners.

Copyright Information and Modifications Policy

This manual is copyright protected. All rights reserved. No part of this manual may be used or reproduced in any form, or stored in any database or retrieval system, without prior written consent of OMNI Flow Computers, Inc., Sugarland, Texas, USA. Making copies of any part of this manual for any purpose other than your own personal use is a violation of United States copyright laws and international treaty provisions.

OMNI Flow Computers, Inc., in conformance with its policy of product development and improvement, may make any necessary changes to this document without notice.

Warranty, Licenses and Product Registration

Product warranty and licenses for use of OMNI flow computer firmware and of OmniCom Configuration PC Software are included in the first pages of each Volume of this manual. We require that you read this information before using your OMNI flow computer and the supplied software and documentation.

If you have not done so already, please complete and return to us the product registration form included with your flow computer. We need this information for warranty purposes, to render you technical support and serve you in future upgrades. Registered users will also receive important updates and information about their flow computer and metering system.



Important!

Copyright ©1991-2007 by OMNI Flow Computers, Inc.

All Rights Reserved.

Chapter 1

Overview of Firmware Revisions 22.74/26.74

Turbine / Positive Displacement Liquid Flow Metering Systems (with Meter Factor Linearization)

1.1. Number of Meter Runs - Type of Flowmeters

Minimum 1 run, Maximum 4 runs - Turbine, Positive Displacement Flowmeters. 'Level A' dual channel 'Pulse Fidelity' checking can be performed on all 4 meter runs.

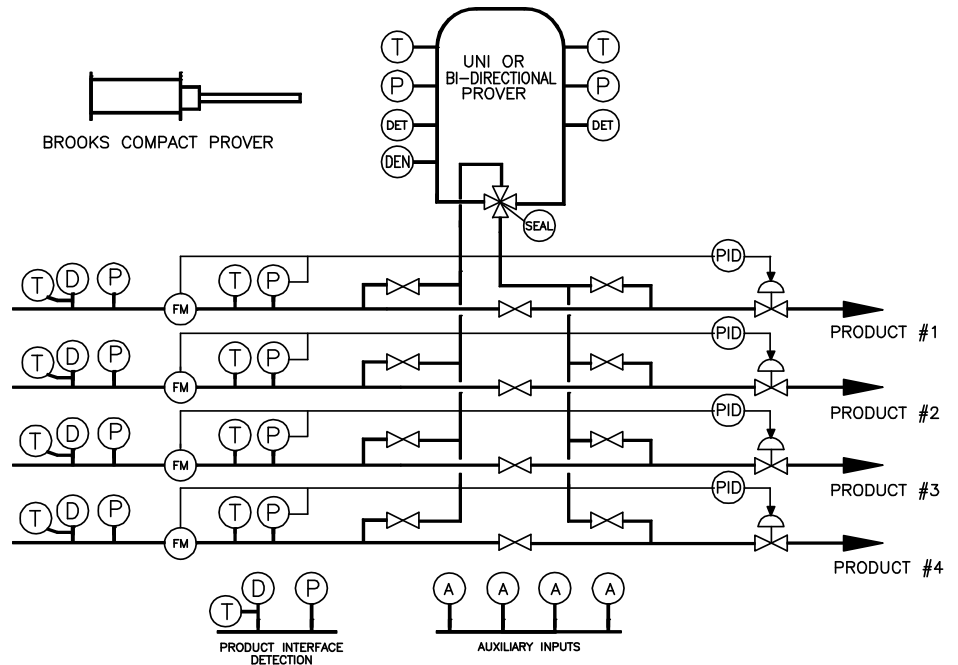

Fig. 1-1. Typical Configuration Using Helical Turbine, Positive Displacement Flowmeters

1.2. Product Configuration

Parallel runs measuring the same product or independent runs with different products.

1.3. Configurable Sensors per Meter Run

Meter Pulses, meter temperature and pressure, meter density, density temperature and pressure.

1.4. Configurable Sensors per Prover

Prover inlet and outlet temperature and pressure, prover densitometer any type (analog or digital pulse type such as Solartron, Sarasota or UGC).

1.5. Temperature

Each temperature sensor can be individually selected to be a 4-20mA, 4-wire DIN curve RTD or 4-wire American curve RTD.

1.6. Densitometers

Can be configured for any combination or mix of individual or shared densitometers of any type (analog or digital pulse type such as Solartron, Sarasota or UGC). The maximum number that can be connected is five. Each analog density can be specified as flowing or reference conditions.

1.7. Station Capability

Meter runs may be combined or subtracted in any mode to provide station flow rates and totalizers.

1.8. Auxiliary Inputs

Four auxiliary inputs are provided for miscellaneous sensors (for example: BS&W, Viscosity monitors, etc.) and can be individually selected to be a 4-20mA, 4-wire DIN curve RTD or 4-wire American curve RTD.

1.9. Number of products - Information Stored/Product

Data for eight products is stored including: product name, meter factors, gravity/density overrides and calculation mode to be used by each flowmeter running the product.

1.10. Type of Products Measured

Crude oil, refined products, NGL's using API 2540, LPG's using GPA TP16, GPA TP27 API 23E/24E, API MPMS 11.1.2004 and API Tables 6, 23 and 54 are also provided.

1.11. Batching and Interface Detection

Six batch setups per meter run can be programmed with alphanumeric batch ID tag, product number to run and expected size of batch.

Individual meter run batch preset down counters provide 'batch end warning' and 'batch end reached' alarms.

Batches can be ended manually or automatically on size of batch, change of product, beginning of new day, day of the week or day of the month.

Product interface detection is achieved using a station interface detector densitometer mounted ahead of the meter runs. 'Line pack' count-down counters allow up to three product interfaces to be tracked between the interface detector gravitometer and the valve manifold allowing pre-emptive product cuts.

1.12. Auto Proving Features

Fully automated proving to API chapter 12. User configured for Uni-, Bi-directional and compact provers with optional inlet and outlet temperature and pressure sensors. Both up-stream and downstream water draw volume inputs are available. Plenum chamber pressure on a Brooks prover is also input as an analog and controlled by the computer. Master meter proving is also featured. Proving can be triggered on change of flow rate versus last known prove for each meter or on the amount of flow which has occurred since the last prove. Proves can also be triggered by a meter being shut in for more than a specified amount of time.

1.13. Retroactive Meter Factors and Override Gravity

Meter factors and override product gravity can be applied retroactively for a selectable number of barrels at any time during a batch. Meter factors determined by a prove can be automatically implemented from that point or retroactively to the beginning of the batch.

1.14. Retroactive Density Correction Factor

Density correction factors can be applied retroactively for a selectable number of barrels at any time during a batch.

1.15. Meter Factor Linearizing Curves

Variations in flowmeter performance due to viscosity and flow rate are corrected by the use of twelve-point meter factor versus flow rate curves. Curves are provided for each meter measuring each product.

1.16. PID Control Functions

Four independent control loops are provided for control of a primary variable with either high or low override control by a secondary variable. Contact closure inputs are activated to provide a startup and shutdown ramp function for each control loop if needed. Primary setpoint can be adjusted via an analog input, a keypad entry or communication link. Control loops are not dedicated and may be cascaded. Data is processed every 500 msec.

1.17. Flow Weighted Averages

Flow weighted averages are calculated for all input variables and correction factors based on hourly, daily totals and running batch totals.

1.18. User-Programmable Digital I/O

Each I/O point is individually configurable as either an input or output with variable 'Delay On' and 'Delay Off'. Pulse widths are adjustable when used as auxiliary totalizer outputs or sampler outputs.

1.19. User-Programmable Logic Functions

Sixty-four logic statements can be user programmed to control meter run switching, prover loop and provide user auxiliary control functions.

1.20. User-Programmable Alarm Functions

Sixteen of the programmable logic statements described above can be used to contain custom text messages which can be displayed, logged and printed.

1.21. User-Programmable Variables

Sixty-four user variables can be programmed to manipulate data for display and printing or remote access via a communication port. Typical uses include special units conversions, customer averaging algorithms for leak detection, special limit checking and control functions. The programmable variable statements can also be used to type cast data of one type to another (i.e., change a floating point variable to an integer type so that a PLC or DCS system can make use of it).

1.22. User Display Setups

The user may specify eight key press combinations which recall display screens. Each user display screen can show four variables each with a descriptive tag defined by the user.

1.23. User Report Templates

Using OmniCom the user can generate custom report templates or edit existing templates. These are uploaded into the flow computer. Custom templates for the snapshot, batch end, daily and prove reports can be defined.

1.24. Serial Communication Links

Up to six serial data links are available for communications with other devices such as printers, SCADA systems, PLC's and other OMNI Flow Computers. Ports communicate using a superset of the Modbus™ protocol (ASCII or RTU). Printer data is ASCII data. Baud rate has been increased to 57600 on all serial ports.

1.25. Peer-to-Peer Communications

OMNI flow computers can be user configured to communicate with each other as equal peers. Groups of data variables can be exchanged or broadcast between other flow computers. Multiple flow computers can share resources such as a PLC.

1.26. Archive Data

Two types of data archiving are possible in the flow computer. 1) Formatted ASCII text using custom report templates, 2) Raw Data using archive records and files.

1.27. OmniCom™ Windows Version Software Communications Package

OmniCom™ software is provided with each flow computer, and allows the user to configure the computer on-line or off-line using a personal computer.

1.28. OmniView™ Windows Version Interface Software Package

A Man-Machine Interface package for the OMNI Flow Computer is also available as an option.

1.29. Ethernet Module

An Ethernet module 68-6209 has been added that will allow users to send reports thru the Ethernet module, or communications via a hub. **See Technical Bulletin TB-020101** for more information.

Chapter 2

Flow Computer Configuration

2.1. Introduction

Configuration data is stored in the computer's battery backed-up RAM memory which will retain its data for at least 1 to 2 months with no power applied. Configuration data can be entered using one of three methods:

- 1) Configure off-line using the OmniCom PC configuration program and then uploading all data at once.
- 2) Configure on-line using the OmniCom PC configuration program which uploads each change as it is entered.
- 3) Enter configuration data via the front panel keypad using the Program Mode.

Methods 1) and 2) require an IBM compatible PC running the OmniCom Configuration Software and are described in **Volume 5** and in OmniCom Help. Method 3) is described here.

2.2. Configuring with the Keypad in Program Mode

2.2.1. Entering the Program Mode

INFO - Key presses are denoted in bold face between brackets; e.g.: the enter key appears in this manual as **[Enter]**.

While in the Display Mode press the **[Prog]** key. The front panel Program LED above the key will glow green and the following selection menu will be displayed on the first three lines of the LCD display.

The 4th line of the display is used to show the user key presses.

Press Keys to Select
Group Entry, or
Press "Prog" to Exit

2.2.2. Changing Data

Data can be accessed using a sequential list of menu prompts or in a random access manner by going directly to a specific group of entries.

2.2.3. Menu Selection Method

INFO - Characters in '[']' refer to key presses.

TIP - It is best to use the menu selection method when programming an application for the first time as every possible option and variable will be prompted. Once a computer is in operation and you become familiar with the application you can decide to use the faster Random Access Method described on the facing page. While in the Program Mode (program LED on) press **[Setup] [Enter]**. A menu similar to the following will be displayed.

```

***  SETUP MENU  ***
Misc Configuration _
Time/Date Setup
Station Setup
Meter Run Setup
Temperature Setup
Pressure Setup
Grav/Density Setup
PID Control Setup
Prover Setup
Product Setup
Batch Preset Setup
Batch Sequence
Factor Setup
Printer Setup

```

Use the **[↑/↓]** (up/down arrow) keys to move the cursor to the appropriate entry and press **[Enter]** to access a particular submenu. The first menu, 'Misc Configuration', should always be completed first as these entries specify the number and type of input and output devices connected to the flow computer; i.e., the menus following the 'Misc Configuration' menu do not ask for configuration data unless a transducer has been defined.

2.2.4. Random Access Method

In addition to the Setup Menu, the data is also presented in related groups such as Temperature, Pressure, Meter, etc. You press the group key of your choice to get to a data area. By specifying a meter run before or after a group you go directly to the data for that group and that group only.

Once a group is selected use the 'Up/Down' arrow keys to step to a specific data entry within the group. You can view data and, assuming a valid password has been entered, change its value as required. If an error is made, press **[Clear]**, re-enter the correct data and press **[Enter]** to enter the new value. The cursor will automatically step to the next data item in that group unless that would cause a total change of screen (i.e., you can always verify your entry). A list of data groups and associated key presses is listed later in this chapter.

Example:

Pressing **[Temp]** will allow you access to temperature data for all meter runs. Pressing **[Meter] [1] [Temp]** or **[Temp] [Meter] [1]** will allow access to only Meter Run #1 temperature data. For example, pressing **[Meter] [1] [Temp]** will display the following until the **[Enter]** key is pressed.

```

Press Keys to Select
Group Entry, or
Press "Prog" to Exit
Meter 1 Temp

```

The 4th line of the display is used to show the user key presses.

Pressing the **[Enter]** key will display a screen similar to this:

```

TEMPERATURE#1 Deg.F
Low Limit      30.0
High Limit     125.0
Override       60.0
  
```

INFO - Most entry groups occupy multiple screens so be sure to use the **[↑]/[↓]** to scroll and see all data.

2.2.5. Passwords

Except when changing transducer high/low alarm limits, a password is usually asked for when changing the configuration data within the computer.

The flow computer has independent password protection of the following:

- o Local Keypad Access / Modbus Port #1 (selectable)
(Physical Serial Port #1)
- o Modbus Port #2 - (Physical Serial Port #2)
- o Modbus Port #3 - (Physical Serial Port #3)
- o Modbus Port #4 - (Physical Serial Port #4)

Local Keypad Access

Three password levels are provided:

- θ Privileged Level Allows complete access to all entries within the flow computer including keypad passwords 1, 1A and 2 below. The initial privileged password for each Modbus port is selected via this password level.
- θ Level 1 This level allows technician access to most entries within the flow computer with the exception of I/O Points assignments, programmable variables and Boolean statements and passwords other than 'Keypad Level 1'.
- θ Level 1A This level allows technician access to the following entries only:
 - ◆ Meter Factors
 - ◆ K Factors
 - ◆ Densitometer Correction Factors (Pycnometer Factor)
- θ Level 2 Allows access to the operator type entries. These entries include:
 - ◆ Transducer Manual Overrides
 - ◆ Product Gravity Overrides
 - ◆ Prover Operations
 - ◆ Batching Operations

INFO - Characters in '[']' refer to key presses.

INFO - See Technical Bulletin **TB-960701** in **Volume 5** for setting Level B and Level C passwords using OmniCom.

Note: Level B and Level C passwords for each Modbus port cannot be viewed or changed from the keypad.

INFO - The Help System is not limited to just the Program Mode. Context sensitive help is available in all modes of operation.

Changing Passwords at the Keypad

- 1) At the keypad press **[Prog] [Setup] [Enter]**.
 - 2) With the cursor blinking on **'Misc Configuration'**, press **[Enter]**.
 - 3) With the cursor blinking on **'Password Maint?'**, press **[Enter]**.
 - 4) Enter the Privileged Level Password (up to 6 Characters) and press **[Enter]**.
 - 5) The Level 1, 1A and Level 2 passwords can now be viewed and changed if required.
- 1) Scroll down to access each of the Modbus serial port 'Level A' passwords. These are labeled 'Serial 1' (if Modbus Protocol is selected), 'Serial 2', 'Serial 3', and 'Serial 4' corresponding to the physical port numbering for Modbus Ports 1, 2, 3 and 4.

2.3. Getting Help

Context sensitive help is available for most data entries. Help is summoned by pressing the **[Display/Enter]** key twice (**[Help]** key) with the cursor on the data field in question. Help screens are frequently more than 1 full screen so always use the **[↑]/ [↓]** keys to scroll in case there is more. Press **[Prog]** or **[Enter]** once to exit the help system and return to your original screen.

2.4. Program Inhibit Switch

A 'Program Inhibit Switch' mounted behind the front panel prevents unauthorized changing of data when in the 'Inhibit' position. Most data can be viewed while the switch is in the program inhibit position, but any attempt to alter data will be ignored and cause 'PROGRAM LOCKOUT' to be displayed on the bottom line of the LCD display.

The inner enclosure of the flow computer can be locked or sealed within the outer enclosure blocking access to the 'Program Inhibit Switch'.

CAUTION!

These units have an integral latching mechanism which first must be disengaged by lifting the bezel upwards before withdrawing the unit from the case.

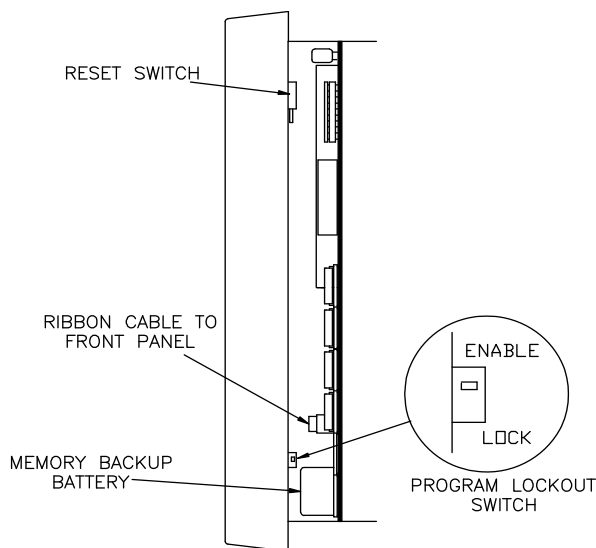

Fig. 2-1. Figure Showing Program Inhibit Switch

2.5. Configuring the Physical Inputs / Outputs

Tip - It is best to use the Menu Selection Method (see 2.2.3) when programming an application for the first time as every possible option and variable will be prompted. Once a computer is in operation and you become familiar with the application you can decide to use the faster Random Access Method (see 2.2.4).

INFO - Characters in '[']' refer to key presses.

INFO - The first menu, 'Misc Configuration', should always be completed first as these entries specify the number and type of input and output devices connected to the flow computer. You are advised to complete all entries under this menu before proceeding. Only transducers that have been assigned to physical I/O points will be available for further configuration (i.e., the menus following the 'Misc Configuration' menu do not ask for or accept configuration data unless a transducer has been defined). (See 2.5.2.)

The OMNI Flow Computer can accept many I/O modules and be configured to match just about any combination of measurement transmitters. Configuring the physical I/O means setting up the number of meter runs, what types of transducers are to be used and to which physical I/O points they are connected.

2.5.1. Miscellaneous Configuration (Misc. Setup Menu)

The physical I/O configuration of the flow computer is changed by entering the 'Misc. Setup' menu while the 'Select Group Entry' screen is displayed (see 2.2.1. "Entering the Program Mode").

```
Press Keys to Select
Group Entry, or
Press "Prog" to Exit
Setup
```

Press **[Setup]** then **[Enter]** and the following selection menu will be displayed:

```
*** SETUP MENU ***
Misc Configuration _
Time/Date Setup
Station Setup
```

The cursor automatically appears at the 'Misc Configuration' option. Press **[Enter]** and the following selection menu will be displayed:

```
*** Misc. Setup ***
Password Maint?(Y)
Check Modules?(Y)
Config Station?(Y)
Config Meter "n"
Config Prove?(Y)
Config PID?"n"
Config D/A Out"n"
Front Pnl Counters
Program Booleans?
Program Variables?
User Display?"n"
Config Digital"n"
Serial I/O "n"
Peer/Peer Comm(Y)?
Custom Packet "n"
Archive File "n"
PLC Group "n"
```

2.5.2. Physical I/O Points not Available for Configuration

Configuration parameter groups are only prompted as needed. Meter runs and transducers which are not assigned to a physical I/O point will not be available for configuration. In these cases the following message will be displayed:

If this message is displayed check the I/O point assignment for the variable.

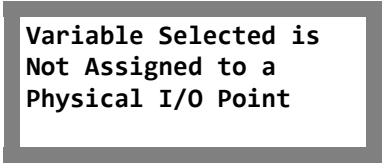

2.5.3. Password Maintenance Settings

INFO - Characters in '{ }' refer to password levels. Characters in '[]' refer to key presses.

TIP - Use the blank lines provided next to each configuration option to write down the corresponding settings you entered in the flow computer. Some of these entries may not appear on the display or in OmniCom. Depending on the various configuration settings of your specific metering system, only those configuration options which are applicable will be displayed.

Note: In the privileged password area all passwords are legible upon entering the correct privileged password. In all other cases when requested for a password, upon entering the password, the OMNI will display all entered characters as asterisk.

Password maintenance settings can only be entered via the OMNI front panel keypad. Enter [Y] at 'Password Maint ?' of the 'Misc Setup' menu to open the following entries:

- {PL} Privileged** _____
Enter the privileged password to allow you to view and change all configuration data including other passwords.
- {PL} Level 1** _____
Enter the Level 1 password to allow entry of all configuration data except entries which determine the physical I/O personality of the computer.
- {PL} Level 1A** _____
Enter the Level 1A password to allow entry of Meter factors, K Factors and Density Correction Factors only.
- {PL} Level 2** _____
Enter the Level 2 password which is required for operator type entries such as gravity overrides and meter factors.
- {PL} Serial Port #1 Password** _____
Enter the Serial Port password. All data in the Modbus database except passwords can be read via the serial ports. These passwords allow writes to the Modbus database. Password protection can be disabled by entering a blank field as a password.
- {PL} Lockout Switch Active? (Serial Port #1)** _____
Enter [N] for the lockout switch to be **inactive** for this serial port.
Enter [Y] for the lockout switch to be **active** for this serial port.
- {PL} Serial Port #2 Password** _____
Enter the Serial Port #2 Password.
- {PL} Lockout Switch Active? (Serial Port #2)** _____
- {PL} Serial Port #3 Password** _____
- {PL} Lockout Switch Active? (Serial Port #3)** _____
- {PL} Serial Port #4 Password** _____
- {PL} Lockout Switch Active? (Serial Port #4)** _____

{PL} Serial Port #5 Password _____

{PL} Lockout Switch Active? (Serial Port #5) _____

{PL} Serial Port #6 Password _____

{PL} Lockout Switch Active? (Serial Port #6) _____

2.5.4. Entries Requiring a Valid Privileged Password

The following entries display only when a Valid Privileged Password is entered:

{PL} Model Number (0=3000, 1=6000) _____

This entry is used by the OmniCom configuration software to determine the maximum I/O capability of the computer.

{PL} Re-configure Archive _____

Enter [Y] to re-configure archive records definition. Enter [N] when finished.

{PL} Archive Run (Y/N) _____

Enter [Y] to start the archive running.

{PL} Delay Cycle 0-20 _____

Enter a number between 0-20 as number of 500ms cycle delays to differentiate between simultaneous noise with A=0 and an A failure., with Dual pulse fidelity Alarms.

{PL} Reset All Totalizers ? (Y/N) _____

Entering Y will reset all current meter totalizers to 0.0. Once this has been done the user will see another display " All Totalizers now reset" and the user can now select the totalizers resolution # of digits, 0=9, and 1=8. Next the user can select the decimal place resolution for the front panel by selecting the number of decimal places required for Gross, Net and Mass. The three electromechanical totalizers on the front of the computer cannot be zeroed.

{PL} Reset All RAM ? (Y/N) _____

Resetting all RAM will clear all configuration data, calibration data and totalizers. This means that all configuration data will have to be re-entered.

{PL} Input Calibrate Default ? _____

Entering a [Y] here will set all the analog input calibration constants used to scale zero and span settings to the default value. This will require you to re calibrate all the inputs. **You can also do this on a channel by channel basis by entering the input channel number.**

{PL} D/A Calibrate Default ? _____

Entering a [Y] here will set all the analog output calibration constants used to scale zero and span settings to the default value. This will require you to re-calibrate all the outputs. **You can also do this on a channel by channel basis by entering the output channel number.**

INFO - Characters in '{ }' refer to password levels. Characters in '[]' refer to key presses.

TIP - Use the blank lines provided next to each configuration option to write down the corresponding settings you entered in the flow computer.

Some of these entries may not appear on the display or in OmniCom. Depending on the various configuration settings of your specific metering system, only those configuration options which are applicable will be displayed.

CAUTION!

If you change the number or type of installed I/O modules, you must perform the 'Check Modules' Function to inform the computer that you wish to use the new hardware configuration.

2.5.5. Module Settings

Enter [Y] at 'Check Modules ?' of the 'Misc Setup' menu and a screen similar to the following will display:

MODULE	S-WARE	H-WARE
A-1	Y	Y
D-2	Y	N
S-2	Y	Y
Update S-Ware ?		

{PL} Update S-Ware ? (Y)

A table is displayed showing all of the physically installed I/O modules versus the I/O modules recognized by the software (see display example above). You must answer the 'Update Software' question entering [Y] whenever you change the number or type of installed modules. The available I/O point numbers are allocated to each module at this time according to the type and number of each module (see **Chapter 2** for more information).

2.5.6. Meter Station Settings

Enter [Y] at 'Config Station ?' of the 'Misc Setup' menu to open the following entries:

{PL} Station Configured As:

Station Totals and Flows Defined As: Define which meter runs will be included in the station flow rates and totalizers. Meter data can be added or subtracted.

Example: Entering [1] [+] [2] [-] [3] [-] [4] defines the station flows and totals as the result of Meter Runs #1 and #2 added together, subtracted by the flows of Meters #3 and #4.

Enter [0] for no station totalizers.

{PL} Density I/O Point Number

Enter the I/O point number that corresponds to the station density or gravity input used as the product interface detector. Digital densitometers can be corrected for temperature and pressure effects using the station pressure and temperature points. Digital pulse densitometers can only be assigned I/O point numbers corresponding to the 4th input channel of a B Type Combo Module, or Channels 3 or 4 of an E/D Type Combo Module.

Densitometer Tag

Enter the 8-character tag name used to identify this density transducer on the LCD display.

Densitometer Type

Enter the densitometer type:

- 0 = No density type selected
- 1 = 4-20mA output signal linear with API gravity units (many API devices are actually designed to drive non-linear API chart recorders; they are usually linear with relative density units)
- 2 = 4-20mA output signal linear with relative density (SG) units
- 3 = 4-20mA output signal linear with grs/cc density
- 4 = Solartron digital pulse
- 5 = Sarasota digital pulse
- 6 = UGC digital pulse.

INFO - Characters in '{ }' refer to password levels. Characters in '[]' refer to key presses.

TIP - Use the blank lines provided next to each configuration option to write down the corresponding settings you entered in the flow computer.

Some of these entries may not appear on the display or in OmniCom. Depending on the various configuration settings of your specific metering system, only those configuration options which are applicable will be displayed.

INFO - The number of process variable I/O points available depends on the number of combo modules installed (see **Chapter 2** in **Volume 1** for more information). Point numbers range from 01 through 24. Assign **[0]** to 'invalidate the assigning of a variable.

I/O Type Mismatch - The computer will not let you assign the same I/O point # to incompatible transducer types; i.e., an I/O point cannot be assigned as a temperature input for Meter Run #1 and a pressure input for Meter Run #2. If the 'I/O Type Mismatch' message is displayed, recheck the I/O.

Shared Transducers - Enter the same I/O point to share transducers between meter runs.

Correcting a Mistake - Enter an I/O point # of **[0]** to cancel an incorrectly entered I/O point #, then enter the correct number.

{PL} Density Temperature I/O Point Number _____

Enter the I/O point number to which the temperature sensor used to compensate the station densitometer is connected.

When a digital densitometer is used as the station transducer, it can be corrected for temperature effects by assigning a temperature I/O point.

For the station product interface densitometer, enter a meter run temperature sensor in cases where a separate temperature transmitter is not available.

RTD probes should be assigned to the 1st channel on any type of combo module. RTD probes can also be assigned to the 2nd channel of B Type combo modules.

Density Temperature Tag _____

Enter the 8-character tag name used to identify this density temperature transducer on the LCD display.

Density Temperature Type _____

Enter the densitometer temperature transmitter type:

- 0 = RTD probes that follow the DIN curve and $\alpha = 0.0385$
- 1 = RTD probes that follow the American curve and $\alpha = 0.0392$
- 2 = Honeywell smart transmitter connected to an 'H' combo module or a transducer with a 4-20mA linear output

{PL} Density Pressure I/O Point Number _____

Enter the I/O point number to which the pressure transmitter used to compensate the station digital densitometers is connected.

When a digital densitometer is used as the product interface detector, it can be corrected for pressure effects by assigning a station pressure point.

If a separate pressure transmitter is not available, enter a meter pressure transmitter I/O point.

Density Pressure Tag _____

Enter the 8-character tag name used to identify this density pressure transducer on the LCD display.

Auxiliary Input Assignment

INFO - Characters in '{ }' refer to password levels. Characters in '[]' refer to key presses.

TIP - Use the blank lines provided next to each configuration option to write down the corresponding settings you entered in the flow computer. Some of these entries may not appear on the display or in OmniCom. Depending on the various configuration settings of your specific metering system, only those configuration options which are applicable will be displayed.

INFO - The number of process variable I/O points available depends on the number of combo modules installed (see **Chapter 2** in **Volume 1** for more information). Point numbers range from 01 through 24. Assign **[0]** to 'invalidate the assigning of a variable.

I/O Type Mismatch - The computer will not let you assign the same I/O point # to incompatible transducer types; i.e., an I/O point cannot be assigned as a temperature input for Meter Run #1 and a pressure input for Meter Run #2. If the 'I/O Type Mismatch' message is displayed, recheck the I/O.

Shared Transducers - Enter the same I/O point to share transducers between meter runs.

Correcting a Mistake - Enter an I/O point # of **[0]** to cancel an incorrectly entered I/O point #, then enter the correct number.

{PL} Auxiliary Input #1 I/O Point Number _____
 Enter the physical I/O point number to which this auxiliary input is connected. Auxiliary Inputs can be used to enter S&W, viscosity and other miscellaneous variables.
 Enter the 8-character tag name used to identify this transducer on the LCD display.

Auxiliary Input #1 Type _____
 Enter the Auxiliary Input Type:
 0 = RTD probes that follow the DIN curve and $\alpha = 0.0385$
 1 = RTD probes that follow the American curve and $\alpha = 0.0392$
 2 = Transducer with a 4-20mA linear output or Honeywell smart transmitter connected to an 'H' combo module

{PL} Auxiliary Input #2 I/O Point Number _____
Auxiliary Input #2 Tag _____
Auxiliary Input #2 Type _____

{PL} Auxiliary Input #3 I/O Point Number _____
Auxiliary Input #3 Tag _____
Auxiliary Input #3 Type _____

{PL} Auxiliary Input #4 I/O Point Number _____
Auxiliary Input #4 Tag _____
Auxiliary Input #4 Type _____

INFO - Characters in '{ }' refer to password levels. Characters in '[]' refer to key presses.

TIP - Use the blank lines provided next to each configuration option to write down the corresponding settings you entered in the flow computer. Some of these entries may not appear on the display or in OmniCom. Depending on the various configuration settings of your specific metering system, only those configuration options which are applicable will be displayed.

Meter #1 **Meter #2** **Meter #3** **Meter #4**

{PL} Densitometer Type _____

Enter the Densitometer Type:

- 0 = No density type selected
- 1 = 4-20mA output signal linear with API gravity units (many API devices are actually designed to drive non-linear API chart recorders; they are usually linear with relative density units)
- 2 = 4-20mA output signal linear with relative density (SG) units
- 3 = 4-20mA output signal linear with grs/cc density
- 4 = Solartron digital pulse
- 5 = Sarasota digital pulse
- 6 = UGC digital pulse.

{PL} Flowing/Reference Conditions _____

This entry applies only if you selected a 4-20mA type densitometer in the previous entry. Specify if the density transducer signal represents density at:

- 0 = Flowing temperature and pressure
- 1 = Reference temperature and pressure

{PL} Density Temp I/O Point # _____

Enter the I/O point number used to input the signal applied to compensate for temperature effects at the densitometer for each meter run.

If the densitometer has no temperature sensor fitted, enter the same I/O point assignment as the meter run temperature sensor.

{PL} Density Temperature Tag _____

Enter the 8-character tag name used to identify this density temperature transducer on the LCD display.

{PL} Density Temperature Type _____

Enter the Densitometer Temperature Transmitter Type:

- 0 = RTD probes that follow the DIN curve and $\alpha = 0.0385$
- 1 = RTD probes that follow the American curve and $\alpha = 0.0392$
- 2 = Honeywell smart transmitter connected to an 'H' combo module or a transducer with a 4-20mA linear output

{PL} Density Pressure I/O Point # _____

Enter the I/O point number used to input the signal applied to compensate for pressure effects at the densitometer for each meter run.

If the densitometer has no pressure sensor fitted, enter the same I/O point assignment as the meter run pressure sensor.

{PL} Density Pressure Tag _____

Enter the 8-character tag name used to identify this density pressure transducer on the LCD display.

2.5.8. Prover Settings

INFO - Characters in '{ }' refer to password levels. Characters in '[]' refer to key presses.

TIP - Use the blank lines provided next to each configuration option to write down the corresponding settings you entered in the flow computer. Some of these entries may not appear on the display or in OmniCom. Depending on the various configuration settings of your specific metering system, only those configuration options which are applicable will be displayed.

Configuring the Prover - When an input and output transducer signal is available, the computer uses the average of both signals. Otherwise, it uses the signal from the available transducer. The pressure or temperature of the meter run being proved will be used to compensate the prover if either left or right transducer is assigned to an I/O point #.

Enter [Y] at 'Config Prove ?' of the 'Misc Setup' menu to open the following entries:

- | | <u>Inlet</u> | <u>Outlet</u> |
|--|--------------|---------------|
| {PL} Prover Temperature I/O Point Number _____ | | |
| Enter the I/O point number used to input the prover inlet/outlet temperature signal. Inlet and outlet temperature sensor readings are averaged to determine the actual prover temperature. To use the meter run temperature, enter [0] for both inlet and outlet. If there is only one temperature sensor, enter [0] for outlet or enter the same number for both prover inlet and outlet. | | |
| {PL} Prover Temperature Transducer Tag _____ | | |
| Enter the 8-character tag name used to identify this temperature transducer on the LCD display. | | |
| {PL} Prover Temperature Transmitter Type _____ | | |
| Enter the Prover Temperature Transmitter Type:
0 = RTD probes that follow the DIN curve and $\alpha = 0.0385$
1 = RTD probes that follow the American curve and $\alpha = 0.0392$
2 = Honeywell smart transmitter connected to an 'H' combo module or a transducer with a 4-20mA linear output | | |
| {PL} Prover Pressure I/O Point Number _____ | | |
| Enter the I/O point number used to input the prover inlet/outlet pressure signal. Inlet and outlet pressure sensor readings are averaged to determine the actual prover pressure. To use the meter run pressure, enter [0] for both inlet and outlet. If there is only one pressure sensor, enter [0] for outlet or enter the same number for both prover inlet and outlet. | | |
| {PL} Prover Pressure Transducer Tag _____ | | |
| Enter the 8-character tag name used to identify this pressure transducer on the LCD display. | | |
| {PL} Prover Plenum Pressure I/O Point Number _____ | | |
| Applies only when a Brooks's compact prover is specified. Enter the I/O point number used to input the compact prover plenum pressure sensor input. | | |
| {PL} Prover Plenum Pressure Tag _____ | | |
| Enter the 8-character tag name used to identify this plenum pressure transducer on the LCD display. | | |

2.5.9. PID Control Settings

Proportional Integral Derivative (PID) -- For practical reasons we refer to PID Control Loops in this manual. However, your flow computer actually performs the Proportional Integral (PI) function and does not apply the derivative term. The addition of the derivative term would greatly complicate tuning of the control loop and besides is not normally applicable to the types of flow and pressure control used in pipelines.

Valid Assignments - Any 32-bit integer or floating point variable within the database can be assigned to be the primary or secondary controlled variable (see **Volume 4** for a complete listing of database addresses and index numbers).

Enter [1], [2], [3] or [4] at 'Config PID ? "n"' of the 'Misc Setup' menu to open the following entries:

Loop #1 Loop #2 Loop #3 Loop #4

{PL} Assign Primary Variable _____

Enter the database index number of the primary variable in the PID loop (see the sidebar).

Remarks _____

Enter a remark in this 16-character field to identify the function of each variable assignment.

{PL} Primary Action (F/R) _____

Enter [F] (forward action) if the value of the primary variable increases as the controller output % increases. Enter [R] (reverse action) if the value of the primary variable decreases as the controller output % increases.

{PL} Remote Setpoint I/O Point # _____

Enter the I/O point number that the remote set point analog signal is connected to (01-24). Assign this point to **99** in cases where the set point will be downloaded via a communication port. Enter [0] if you will not be using a remote setpoint.

{PL} Assign Secondary Variable _____

Enter the database index number of the secondary variable in the PID loop (see the sidebar).

Remarks _____

Enter a remark in this 16-character field to identify the function of each variable assignment.

{PL} Secondary Action (F/R) _____

Enter [F] (forward action) if the value of the primary variable increases as the controller output % increases. Enter [R] (reverse action) if the value of the primary variable decreases as the controller output % increases.

{PL} Error Select (L/H) _____

This entry determines the circumstances under which the primary or secondary variables are controlled. Enter [L] for low or [H] for high error select, according to the following modes:

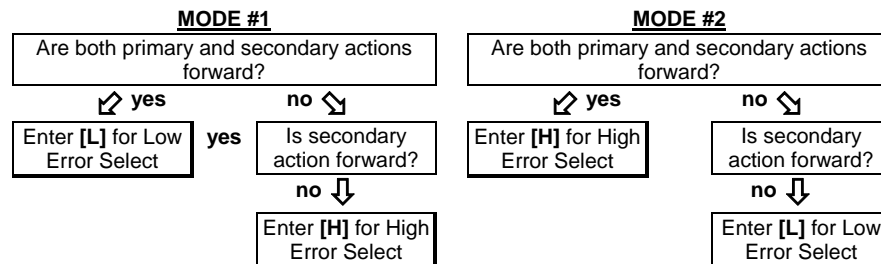

Mode #1: The controller will attempt to control the primary variable but will switch to controlling the secondary variable, should the controller be trying to drive the secondary variable ABOVE its setpoint. An example of this mode would be controlling flow rate (primary) while not exceeding a MAXIMUM delivery pressure (secondary).

Mode #2: The controller will attempt to control primary variable but will switch to controlling the secondary variable, should the controller be trying to drive the secondary variable BELOW its setpoint. An example of this mode would be controlling flow rate (primary) while not dropping below a MINIMUM pressure value (secondary).

{PL} Startup Mode (L/M) _____

This entry determines how the computer handles a system reset such as a momentary loss of power. Enter [L] (Last) to cause the PID loop to stay in the operating mode it was last in before the system reset. Enter [M] (Manual) to cause the PID loop to startup with the PID loop in manual control mode and with the valve open % as it was before the system reset.

{PL} PID Tag _____

Enter an 8-character tag name to identify the PID controller output signal on the LCD display.

2.5.10. Analog Output Settings

INFO - Characters in '{ }' refer to password levels. Characters in '[]' refer to key presses.

TIP - Use the blank lines provided next to each configuration option to write down the corresponding settings you entered in the flow computer. Some of these entries may not appear on the display or in OmniCom. Depending on the various configuration settings of your specific metering system, only those configuration options which are applicable will be displayed.

Press [*n*] [Enter] at 'Config D/A Out "*n*"' of the 'Misc Setup' menu to open the following entries (*n* = Analog Output #1 through #12):

Assign @ 4mA @ 20mA

{L1} Analog Output #1 _____

Under '**Assign**', enter the database index number of the variable that will be assigned to the digital-to-analog output points.

Under '**at 4mA**' and '**at 20mA**', enter the required scaling parameters in engineering units at 4mA and 20mA (e.g.: For Meter #1 Net Flow Rate assigns **7102**. Typical scaling might be 4mA=0.0 bbls/hr and 20mA=1000.0 bbls/hr).

Remark _____

Enter a remark in this 16-character field which identifies and documents the function of each digital-to-analog output.

{L1} Analog Output #2 _____

{L1} Remark _____

{L1} Analog Output #3 _____

{L1} Remark _____

{L1} Analog Output #4 _____

{L1} Remark _____

{L1} Analog Output #5 _____

{L1} Remark _____

{L1} Analog Output #6 _____

{L1} Remark _____

{L1} Analog Output #7 _____

{L1} Remark _____

{L1} Analog Output #8 _____

{L1} Remark _____

{L1} Analog Output #9 _____

{L1} Remark _____

{L1} Analog Output #10 _____

{L1} Remark _____

{L1} Analog Output #11 _____

{L1} Remark _____

{L1} Analog Output #12 _____

{L1} Remark _____

2.5.11. Front Panel Counter Settings

Enter [Y] at 'Front Pnl Counters' of the 'Misc Setup' menu to open the following entries:

Counter A Counter B Counter C

{L1} Assign Front Panel Counter _____

Enter the database index number of the accumulator variable that will be output to this electromechanical counter.

The unit of measure is the same as that shown on the LCD for the totalizer (i.e., barrels, klbs, m³, etc.) The maximum count rate is limited to 10 counts per second. Count rates higher than 10 pulses per second will cause the computer to remember how many counts did not get output and continue to output after the flow stops until all buffered counts are output.

{L1} Remarks _____

Enter a remark in this 16-character field which identifies and documents the function of each front panel counter.

{L1} Pulses/Unit _____

Enter the number of pulses per unit (volume, mass, energy).

2.5.12. Programmable Boolean Statements

Enter [Y] at 'Program Booleans ?' of the 'Misc Setup' menu to open the following entries:

Program Booleans - These 64 Boolean statements are evaluated every 100 msec starting at Point **1025** continuing through **1088**. Each statement can contain up to 3 Boolean variables, optionally preceded by the slash (/) denoting the **NOT** Function and separated by a valid Boolean operator:

Operator	Symbol
NOT	/
AND	&
OR	+
EXOR	*
EQUAL	=
IF)
GOTO	G
MOVE	:
COMPARE	%
INDIRECT	"
RISING EDGE	(
FALLING EDGE	/
ONE SHOT	@

E.g.: 1025 1002&/1003
 Boolean **1025** is true when point **1002** is true **AND** point **1003** is **NOT** true.
Note: Points **1002** and **1003** in this example reflect the status of Physical Digital I/O Points 2 and 3.
 There are no limitations as to what Boolean points can be used in a statement.
 Statements can contain the results from other statements.
E.g.: 1026 /1025+1105
 Boolean **1026** is true when Boolean **1025** is **NOT** true **OR** Point **1105** is true.
 Using the '=' operator, the result of a statement can initiate a command.
E.g.: 1027 1719=1026
 Request a 'Snapshot Report' when Boolean **1026** is true.

Note: See Volume 4 for detailed list of Booleans and Status Commands.

<u>Boolean Point 10xx</u>	<u>Equation or Statement</u>	<u>Comment or Remark</u>
{PL} 25:	_____	_____
{PL} 26:	_____	_____
{PL} 27:	_____	_____
{PL} 28:	_____	_____
{PL} 29:	_____	_____
{PL} 30:	_____	_____
{PL} 31:	_____	_____
{PL} 32:	_____	_____
{PL} 33:	_____	_____
{PL} 34:	_____	_____
{PL} 35:	_____	_____
{PL} 36:	_____	_____
{PL} 37:	_____	_____
{PL} 38:	_____	_____
{PL} 39:	_____	_____
{PL} 40:	_____	_____
{PL} 41:	_____	_____
{PL} 42:	_____	_____
{PL} 43:	_____	_____
{PL} 44:	_____	_____
{PL} 45:	_____	_____
{PL} 46:	_____	_____
{PL} 47:	_____	_____
{PL} 48:	_____	_____
{PL} 49:	_____	_____
{PL} 50:	_____	_____
{PL} 51:	_____	_____
{PL} 52:	_____	_____
{PL} 53:	_____	_____
{PL} 54:	_____	_____
{PL} 55:	_____	_____

TIP - Use the blank lines provided next to each configuration option to write down the corresponding settings you entered in the flow computer.

Program Booleans - These 64 Boolean statements are evaluated every 100 msec starting at Point **1025** continuing through **1088**. Each statement can contain up to 3 Boolean variables, optionally preceded by the slash (/) denoting the **NOT** Function and separated by a valid Boolean operator:

Operator	Symbol
NOT	/
AND	&
OR	+
EXOR	*
EQUAL	=
IF)
GOTO	G
MOVE	:
COMPARE	%
INDIRECT	"
RISING EDGE	(
FALLING EDGE	/
ONE SHOT	@

E.g.: 1025 1002&/1003
 Boolean **1025** is true when point **1002** is true **AND** point **1003** is **NOT** true.

Note: Points **1002** and **1003** in this example reflect the status of Physical Digital I/O Points 2 and 3.

There are no limitations as to what Boolean points can be used in a statement. Statements can contain the results from other statements.

E.g.: 1026 /1025+1105
 Boolean **1026** is true when Boolean **1025** is **NOT** true **OR** Point **1105** is true.

Using the '=' operator, the result of a statement can initiate a command.

E.g.: 1027 1719=1026
 Request a 'Snapshot Report' when Boolean **1026** is true.

<u>Boolean Point 10xx</u>	<u>Equation or Statement</u>	<u>Comment or Remark</u>
{PL} 56:	_____	_____
{PL} 57:	_____	_____
{PL} 58:	_____	_____
{PL} 59:	_____	_____
{PL} 60:	_____	_____
{PL} 61:	_____	_____
{PL} 62:	_____	_____
{PL} 63:	_____	_____
{PL} 64:	_____	_____
{PL} 65:	_____	_____
{PL} 66:	_____	_____
{PL} 67:	_____	_____
{PL} 68:	_____	_____
{PL} 69:	_____	_____
{PL} 70:	_____	_____
{PL} 71:	_____	_____
{PL} 72:	_____	_____
{PL} 73:	_____	_____
{PL} 74:	_____	_____
{PL} 75:	_____	_____
{PL} 76:	_____	_____
{PL} 77:	_____	_____
{PL} 78:	_____	_____
{PL} 79:	_____	_____
{PL} 80:	_____	_____
{PL} 81:	_____	_____
{PL} 82:	_____	_____
{PL} 83:	_____	_____
{PL} 84:	_____	_____
{PL} 85:	_____	_____
{PL} 86:	_____	_____
{PL} 87:	_____	_____
{PL} 88:	_____	_____

2.5.13. Programmable Variable Statements

Enter [Y] at 'Program Variables ?' of the 'Misc Setup' menu to open the following entries:

Programmable Variables -
 These 64 variable statements are evaluated every 500 msec starting at the statement that determines the value of Points **7025** through **7088**. Each statement can contain up to 3 variables or constants. Variables can be optionally preceded by the '\$' symbol denoting the **ABSOLUTE** value of the variable is to be used. Constants are identified by placing a '#' symbol ahead of the number. These and other operators are:

Operator	Symbol
ABSOLUTE	\$
CONSTANT	#
POWER	&
MULTIPLY	*
DIVIDE	/
ADD	+
SUBTRACT	-
EQUAL	=
IF)
GOTO	G
MOVE	:
COMPARE	%
INDIRECT	"

The order of precedence is:
 1) ABSOLUTE
 2) POWER
 3) MULTIPLY/DIVIDE
 4) ADD/SUBTRACT

In cases where operators have the same precedence, statements are evaluated left to right.

E.g.: The value of floating point variable **7035** is defined as:
7035:7027�.5*7026

The power operator is evaluated first (the value of Point **7035** is set equal to the square root of the number contained in Point **7027**) and the result is multiplied by the number stored in variable **7026**. Note that statements can contain the results of other statements. (See OmniCom Help for more information by pressing [F1] on your PC keyboard in the "Configure Variable Statement" menu.)

<u>Prog Variable 70xx</u>	<u>Equation or Statement</u>	<u>Comment or Remark</u>
{PL} 25:	_____	_____
{PL} 26:	_____	_____
{PL} 27:	_____	_____
{PL} 28:	_____	_____
{PL} 29:	_____	_____
{PL} 30:	_____	_____
{PL} 31:	_____	_____
{PL} 32:	_____	_____
{PL} 33:	_____	_____
{PL} 34:	_____	_____
{PL} 35:	_____	_____
{PL} 36:	_____	_____
{PL} 37:	_____	_____
{PL} 38:	_____	_____
{PL} 39:	_____	_____
{PL} 40:	_____	_____
{PL} 41:	_____	_____
{PL} 42:	_____	_____
{PL} 43:	_____	_____
{PL} 44:	_____	_____
{PL} 45:	_____	_____
{PL} 46:	_____	_____
{PL} 47:	_____	_____
{PL} 48:	_____	_____
{PL} 49:	_____	_____
{PL} 50:	_____	_____
{PL} 51:	_____	_____
{PL} 52:	_____	_____
{PL} 53:	_____	_____
{PL} 54:	_____	_____
{PL} 55:	_____	_____

TIP - Use the blank lines provided next to each configuration option to write down the corresponding settings you enter in the flow computer.

Note: See **Volume 4** for detailed list of Booleans and Status Commands

Valid Numeric Variables - These are any long integer or floating point number within the database (Points **5000-8999**), **including Boolean variables.** For the purpose of evaluation, Boolean variables have the value of 1.0 if they are True and 0.0 if they are False.

<u>Prog Variable 70xx</u>	<u>Equation or Statement</u>	<u>Comment or Remark</u>
{PL} 56:		
{PL} 57:		
{PL} 58:		
{PL} 59:		
{PL} 60:		
{PL} 61:		
{PL} 62:		
{PL} 63:		
{PL} 64:		
{PL} 65:		
{PL} 66:		
{PL} 67:		
{PL} 68:		
{PL} 69:		
{PL} 70:		
{PL} 71:		
{PL} 72:		
{PL} 73:		
{PL} 74:		
{PL} 75:		
{PL} 76:		
{PL} 77:		
{PL} 78:		
{PL} 79:		
{PL} 80:		
{PL} 81:		
{PL} 82:		
{PL} 83:		
{PL} 84:		
{PL} 85:		
{PL} 86:		
{PL} 87:		
{PL} 88:		

2.5.14. User Display Settings

Valid Index Number Assignments - Any 32-bit integer or floating point variable within the database can be assigned to be viewed via a user display (see **Volume 4** for a complete listing).

Valid Key Press Sequences - You may select a sequence of up to 4 key presses to recall each display. This does not count the [Display/Enter] key press which must be used to signal the end of the sequence. Each key is identified by the red A through Z character on each valid key.

Valid keys are listed below

- [A] - also labeled [Gross]
- [B] - also labeled [Net]
- [C] - also labeled [Mass]
- [D] - also labeled [Energy]
- [E] - also labeled [S.G./API]
- [F] - also labeled [Control]
- [G] - also labeled [Temp]
- [H] - also labeled [Press]
- [I] - also labeled [Density]
- [J] - also labeled [D.P.]
- [K] - also labeled [Orifice]
- [L] - also labeled [Meter]
- [M] - also labeled [Time]
- [N] - also labeled [Counts]
- [O] - also labeled [Factor]
- [P] - also labeled [Preset]
- [Q] - also labeled [Batch]
- [R] - also labeled [Analysis]
- [S] - also labeled [Print]
- [T] - also labeled [Prove]
- [U] - also labeled [Status]
- [V] - also labeled [Alarms]
- [W] - also labeled [Product]
- [X] - also labeled [Setup]
- [Y] - also labeled [Input]
- [Z] - also labeled [Output]

The [↑]/[↓]/[←]/[→] (Up/Down/Left/Right arrow) keys and the [Prog], [Alpha Shift] and [Clear] keys cannot be used in a key press sequence.

Note: The 'A' through 'Z' keys are used simply to identify key presses. The [Alpha Shift] key does not need to be used when recalling user displays.

Enter 1 through 8 for the selected user display at 'User Display ? "n"' of the 'Misc Setup' menu to open the following password Level 1 {L1} entries:

User Display #1 Key Press Sequence [] [] [] []

Using the keys marked A through Z, enter the sequence of key presses needed to recall the selected user display (see the side bar for details). A maximum of 4 keys are allowed. User key press sequences take priority over any existing resident key press sequences.

1st Variable Tag _____

Enter an 8-character tag name used to identify the display variable on the LCD display.

1st Variable Index Number _____

Enter the database index number of the variable that you want to appear on the LCD display. Each variable within the flow computer database is assigned an index number or address. Any Boolean integer or floating point variable within the database can be displayed.

1st Variable Decimal Point Position _____

Enter the number of digits to the right of the decimal point for the variable. Valid entries are 0 through 7. The computer will display each variable using the display resolution that you have selected, except in cases where the number is too large or too small. In either case, the flow computer will adjust the decimal position or default to scientific display mode.

	<u>Tag</u>	<u>Index #</u>	<u>Decimal Points</u>
2 nd Variable	_____	_____	_____
3 rd Variable	_____	_____	_____
4 th Variable	_____	_____	_____

User Display #2 Key Press Sequence [] [] [] []

	<u>Tag</u>	<u>Index #</u>	<u>Decimal Points</u>
1 st Variable	_____	_____	_____
2 nd Variable	_____	_____	_____
3 rd Variable	_____	_____	_____
4 th Variable	_____	_____	_____

User Display #3 Key Press Sequence [] [] [] []

	<u>Tag</u>	<u>Index #</u>	<u>Decimal Points</u>
1 st Variable	_____	_____	_____
2 nd Variable	_____	_____	_____
3 rd Variable	_____	_____	_____
4 th Variable	_____	_____	_____

Valid Index Number Assignments - Any 32-bit integer or floating point variable within the database can be assigned to be viewed via a user display (see **Volume 4** for a complete listing).

Valid Key Press Sequences - You may select a sequence of up to 4 key presses to recall each display. This does not count the **[Display/Enter]** key press which must be used to signal the end of the sequence. Each key is identified by the red A through Z character on each valid key.

Valid keys are listed below
[A] - also labeled **[Gross]**
[B] - also labeled **[Net]**
[C] - also labeled **[Mass]**
[D] - also labeled **[Energy]**
[E] - also labeled **[S.G./API]**
[F] - also labeled **[Control]**
[G] - also labeled **[Temp]**
[H] - also labeled **[Press]**
[I] - also labeled **[Density]**
[J] - also labeled **[D.P.]**
[K] - also labeled **[Orifice]**
[L] - also labeled **[Meter]**
[M] - also labeled **[Time]**
[N] - also labeled **[Counts]**
[O] - also labeled **[Factor]**
[P] - also labeled **[Preset]**
[Q] - also labeled **[Batch]**
[R] - also labeled **[Analysis]**
[S] - also labeled **[Print]**
[T] - also labeled **[Prove]**
[U] - also labeled **[Status]**
[V] - also labeled **[Alarms]**
[W] - also labeled **[Product]**
[X] - also labeled **[Setup]**
[Y] - also labeled **[Input]**
[Z] - also labeled **[Output]**
 The **[↑]/[↓]/[←]/[→]** (Up/Down/Left/Right arrow) keys and the **[Prog]**, **[Alpha Shift]** and **[Clear]** keys cannot be used in a key press sequence.

User Display #4 Key Press Sequence

[] [] [] []

	<u>Tag</u>	<u>Index #</u>	<u>Decimal Points</u>
1 st Variable	_____	_____	_____
2 nd Variable	_____	_____	_____
3 rd Variable	_____	_____	_____
4 th Variable	_____	_____	_____

User Display #5 Key Press Sequence

[] [] [] []

	<u>Tag</u>	<u>Index #</u>	<u>Decimal Points</u>
1 st Variable	_____	_____	_____
2 nd Variable	_____	_____	_____
3 rd Variable	_____	_____	_____
4 th Variable	_____	_____	_____

User Display #6 Key Press Sequence

[] [] [] []

	<u>Tag</u>	<u>Index #</u>	<u>Decimal Points</u>
1 st Variable	_____	_____	_____
2 nd Variable	_____	_____	_____
3 rd Variable	_____	_____	_____
4 th Variable	_____	_____	_____

User Display #7 Key Press Sequence

[] [] [] []

	<u>Tag</u>	<u>Index #</u>	<u>Decimal Points</u>
1 st Variable	_____	_____	_____
2 nd Variable	_____	_____	_____
3 rd Variable	_____	_____	_____
4 th Variable	_____	_____	_____

User Display #8 Key Press Sequence

[] [] [] []

	<u>Tag</u>	<u>Index #</u>	<u>Decimal Points</u>
1 st Variable	_____	_____	_____
2 nd Variable	_____	_____	_____
3 rd Variable	_____	_____	_____
4 th Variable	_____	_____	_____

2.5.15. Digital I/O Point Settings

Enter 1 through 24 for the selected digital I/O Point at 'Config Digital "n"' of the 'Misc Setup' menu to open the following password Level 1 {L1} entries:

TIP - Use the blank lines provided next to each configuration option to write down the corresponding settings you entered in the flow computer. Some of these entries may not appear on the display or in OmniCom. Depending on the various configuration settings of your specific metering system, only those configuration options which are applicable will be displayed.

Config Digital "n" - Assign each physical I/O point to a Modbus address of a Boolean variable. There are no limitations as to what Boolean points can be assigned to physical I/O points. Enter [0] (zero) for Modbus control.

Assigning as Pulse Outputs - Meter and Station Accumulators may be output in the form of pulses.

Pulse Width - Pulse width is measured using 10msec ticks; i.e., 100 = 1 second.

Pulse per Unit - Pulse per unit entry can be used to provide unit conversion (e.g.: entering 4.2 pulses per barrel will give 1 pulse every 10 gallons as there are 42 gallons in a barrel). The units of volume, mass and energy flow are the same as is displayed on the LCD.

Assigning as Control Output - Any internal alarm or Boolean can be output.

	<u>Assign</u>	<u>Pulse Width</u>	<u>Pulse/Unit</u>	or	<u>Delay On</u>	<u>Delay Off</u>
Digital I/O #1	_____	_____	_____		_____	_____
Remark	_____					
Digital I/O #2	_____	_____	_____		_____	_____
Remark	_____					
Digital I/O #3	_____	_____	_____		_____	_____
Remark	_____					
Digital I/O #4	_____	_____	_____		_____	_____
Remark	_____					
Digital I/O #5	_____	_____	_____		_____	_____
Remark	_____					
Digital I/O #6	_____	_____	_____		_____	_____
Remark	_____					
Digital I/O #7	_____	_____	_____		_____	_____
Remark	_____					
Digital I/O #8	_____	_____	_____		_____	_____
Remark	_____					
Digital I/O #9	_____	_____	_____		_____	_____
Remark	_____					
Digital I/O #10	_____	_____	_____		_____	_____
Remark	_____					
Digital I/O #11	_____	_____	_____		_____	_____
Remark	_____					
Digital I/O #12	_____	_____	_____		_____	_____
Remark	_____					

Delay On/Off - Used to delay or stretch a control output. The delay is measured using 100msec ticks; i.e., 10 = 1 second.

Assigning as Status or Command Inputs - Switches, etc., can be used to trigger events within the flow computer, such as end a batch or start a prove sequence (see the facing page for more details).

1700 Dummy Boolean - Assign all physical I/O points which will be used only in Boolean statements for sequencing or control to **1700**. This sets up the points as an input only.

Note: See **Volume 4** for valid assignments.

	<u>Assign</u>	<u>Pulse Width</u>	<u>Pulse/Unit</u> or	<u>Delay On</u>	<u>Delay Off</u>
Digital I/O #13	_____	_____	_____	_____	_____
Remark	_____				
Digital I/O #14	_____	_____	_____	_____	_____
Remark	_____				
Digital I/O #15	_____	_____	_____	_____	_____
Remark	_____				
Digital I/O #16	_____	_____	_____	_____	_____
Remark	_____				
Digital I/O #17	_____	_____	_____	_____	_____
Remark	_____				
Digital I/O #18	_____	_____	_____	_____	_____
Remark	_____				
Digital I/O #19	_____	_____	_____	_____	_____
Remark	_____				
Digital I/O #20	_____	_____	_____	_____	_____
Remark	_____				
Digital I/O #21	_____	_____	_____	_____	_____
Remark	_____				
Digital I/O #22	_____	_____	_____	_____	_____
Remark	_____				
Digital I/O #23	_____	_____	_____	_____	_____
Remark	_____				
Digital I/O #24	_____	_____	_____	_____	_____
Remark	_____				

2.5.16. Serial Input / Output Settings

Baud Rates Available - 300, 600, 1200, 2400, 4800, 9600, 19200, 38400. 57600

Data Bits - 7 or 8 - 7 for ASCII Modbus, 8 for RTU Modbus.

Stop Bits - 0, 1 or 2.

Parity Bit - Odd, Even, None.

Transmitter Carrier Key Delay - Delays are approximate only. 0=msec, 1=50msec, 2=100msec, 3=150msec.

Modbus Type - Select the protocol type which matches the Modbus master device. If the master can support either ASCII or RTU, choose RTU protocol as it is approximately twice as efficient as the ASCII protocol. Serial Ports #3 and #4 have additional protocol options.

Modicon™ Compatible - OmniCom will not operate if downloading configuration with this entry set to 'Y'.

Enter [1], [2], [3] [4] [5] or [6] at 'Serial I/O "n"' of the 'Misc Setup' menu to open the following entries:

{L1} **Baud Rate (Computer Default 9600)**

{L1} **Number of Stop Bits (Computer Default 1)**

{L1} **Number of Data Bits (Computer Default 8)**

{L1} **Parity Bit (Even/Odd/None) (Computer Default N)**

{L1} **Transmit Carrier Key Delay (Computer Default 0)**

Enter one of the following options:

0 = 0 msec delay 2 = 100 msec delay
1 = 50 msec delay 3 = 150 msec delay

You must enter [0] for Transmitter Carrier Key Delay for any port that will be used with a shared printer.

{L1} **Serial Port Type (Computer Port #1 Default =0 Printer)**

This entry corresponds to Serial Port #1 only. Enter one of the following options:

0 = Printer
1 = Modbus RTU

{L1} **Modbus Protocol Type (Computer Default 2)**

This entry does not apply to Serial Port #1. Enter the type of protocol to be used on this port:

0 = Modbus RTU
1 = Modbus ASCII
2 = Modbus RTU (modem).

Serial Port #4 has the following additional options:

3 = Allen Bradley Full Duplex
4 = Allen Bradley Half Duplex

Mixed protocols are not allowed on a communication link. All devices must use the same protocol type. The RTU protocol is preferred as it is twice the speed of the ASCII. Selecting 'Modbus RTU Modem' provides RTU protocol with relaxed timing which is usually needed when communicating via smart modems. These modems have been found to insert inter-character delays which cause a premature end of message to be detected by the flow computer.

IMPORTANT: You must select either 'Modbus RTU' or 'Modbus RTU Modem' protocol for the port that will be used to communicate with OmniCom PC configuration software.

{L1} **Modbus ID (Computer Default 1)**

This entry does not apply to Serial Port #1 when a printer is selected as the port type. Enter the Modbus slave ID number that this serial port will respond to (1 through 247 acceptable). This entry will be disabled for Serial Port #1 if a printer is selected as the port type.

INFO - Characters in '{ }' refer to password levels. Characters in '[]' refer to key presses.

TIP - Use the blank lines provided next to each configuration option to write down the corresponding settings you entered in the flow computer. Some of these entries may not appear on the display or in OmniCom. Depending on the various configuration settings of your specific metering system, only those configuration options which are applicable will be displayed.

Skip CRC/LCR Check - If you have disabled the error checking on incoming messages, you must substitute dummy bytes in the message string. Outgoing messages will always include the error checking bytes.

{L1} Modicon Compatible (Y/N) (Computer Default N)

Enter [Y] to configure these Modbus ports to be compatible with Modicon PLC equipment (e.g.: 984 series) and DCS systems (e.g.: Honeywell TDC3000 systems using the Advanced Process Manager APM-SI). This entry will be disabled for Serial Port #1 if a printer is selected as the port type.

In this mode the point number indexes requested and transmitted while using the Modbus RTU modes are actually one less than the index number documented in this manual. ASCII mode transmissions use the address documented in this manual. Data is counted in numbers of 16 bit registers rather than points. i.e., To request two 4 byte IEEE floating point variables, index numbers 7101 and 7102, would require the host to ask for 4 registers starting at index 7100. IEEE Floating Point data bytes are transmitted in swapped format:

NORMAL IEEE FLOAT FORMAT				ORDER TRANSMITTED			
Byte #1	Byte #2	Byte #3	Byte #4	Byte #1	Byte #2	Byte #3	Byte #4
Biased Exponent	MS Mantissa	Mantissa	LS Mantissa	Mantissa	LS Mantissa	Biased Exponent	MS Mantissa

{L1} CRC Enabled (Computer Default Y)

Many protocols use either a CRC, LRC or BCC error check to ensure that data received is not corrupted. The flow computer can be configured to ignore the error checking on incoming messages. This allows software developers an easy means of debugging communications software. **Error checking should only be disabled temporarily when debugging the master slave communication link.** The computer expects dummy characters in place of the CRC, LRC or BCC.

Enter [Y] to perform error checking on incoming messages. For maximum data integrity always enter [Y] during normal running conditions. Enter [N] to disable error checking on incoming messages. This entry will be disabled for Serial Port #1 if a printer is selected as the port type.

{L1} New Ethernet (Y/N) (Computer Default N)

Allow users to set the mode to work with earlier or newer modules of the Ethernet card. 0=earlier Ethernet modules with 384000 Baud and Only Modbus ID will be entered. 1= Newer Ethernet Modules 57600 Baudrate and additional entries as shown below.

{L1} Modbus ID

Enter the Modbus ID of the Ethernet Module

{L1} IP Address

All devices on a network require a unique IP address. The IP is entered in dotted decimal notation.

{L1} Netmask

IP address contain a Netmask identifier. The Netmask is entered in dotted decimal notation.

{L1} Gateways

If a default gateway exists for accessing other subnets, it can be entered here. The Gateway is entered in dotted decimal notation.

{L1} Reports (Y/N)

Select Y to allow reports to be printed.

{L1} Alarms(Y/N)

Select Y to allow Alarms reports to be printed

2.5.17. Custom Modbus™ Data Packet Settings

INFO - Packets defined are usually read-only and must always be retrieved as a packet. When Modicon 984 is selected these packet setup entries are used to define a logical array of variables which can be read or written in any grouping. The number of data points is always input in terms of OMNI "logical" elements; i.e., an IEEE floating point number comprises two 16-bit words but is considered one logical element.

Custom Modbus Data Packets are provided to reduce the number of polls needed to read multiple variables which may be in different areas of the database. Groups of data points of any type of data can be concatenated into one packet by entering each data group starting index numbers 001, 201 and 401. The number of data bytes in a custom packet in non-Modicon compatible mode cannot exceed 250 (RTU mode) or 500 (ASCII mode). When Modicon compatible is selected, the number of data bytes in a custom packet cannot exceed 400 (RTU mode) or 800 (ASCII mode).

Enter **[1]**, **[2]** or **[3]** to select a data packet at 'Custom Packet "n"' of the 'Misc Setup' menu to open the entries below. Under **Index #**, enter the database address or Modbus index number for each start data point of each group. Under **Points**, enter the number of consecutive data points to include in each data group.

INFO - Characters in '{ }' refer to password levels. Characters in '[]' refer to key presses.

TIP - Use the blank lines provided next to each configuration option to write down the corresponding settings you entered in the flow computer. Some of these entries may not appear on the display or in OmniCom. Depending on the various configuration settings of your specific metering system, only those configuration options which are applicable will be displayed.

Custom Modbus Data Packet #1 (Addressed at 001)

{L1} <u>Index # Points</u>	<u>Index # Points</u>	<u>Index # Points</u>	<u>Index # Points</u>
#1 _____ _____	#2 _____ _____	#3 _____ _____	#4 _____ _____
#5 _____ _____	#6 _____ _____	#7 _____ _____	#8 _____ _____
#9 _____ _____	#10 _____ _____	#11 _____ _____	#12 _____ _____
#13 _____ _____	#14 _____ _____	#15 _____ _____	#16 _____ _____
#17 _____ _____	#18 _____ _____	#19 _____ _____	#20 _____ _____

Custom Modbus Data Packet #2 (Addressed at 201)

{L1} <u>Index # Points</u>	<u>Index # Points</u>	<u>Index # Points</u>	<u>Index # Points</u>
#1 _____ _____	#2 _____ _____	#3 _____ _____	#4 _____ _____
#5 _____ _____	#6 _____ _____	#7 _____ _____	#8 _____ _____

Custom Modbus Data Packet #3 (Addressed at 401)

{L1} <u>Index # Points</u>	<u>Index # Points</u>	<u>Index # Points</u>	<u>Index # Points</u>
#1 _____ _____	#2 _____ _____	#3 _____ _____	#4 _____ _____
#5 _____ _____	#6 _____ _____	#7 _____ _____	#8 _____ _____
#9 _____ _____	#10 _____ _____	#11 _____ _____	#12 _____ _____
#13 _____ _____	#14 _____ _____	#15 _____ _____	#16 _____ _____
#17 _____ _____	#18 _____ _____	#19 _____ _____	#20 _____ _____

2.5.18. Programmable Logic Controller Setup

Note: See *Technical Bulletin TB-960702 "Communicating with Allen-Bradley™ Programmable Logic Controllers"* in Volume 5 for information on the 'PLC Group "n"' submenu.

INFO - Characters in '{ }' refer to password levels. Characters in '[]' refer to key presses.

TIP - Use the blank lines provided next to each configuration option to write down the corresponding settings you entered in the flow computer.

Some of these entries may not appear on the display or in OmniCom. Depending on the various configuration settings of your specific metering system, only those configuration options which are applicable will be displayed.

TIP - For maximum efficiency, always start Modbus ID numbers from 1.

2.5.19. Archive File Setup

Note: See *Technical Bulletin TB-960703 "Storing Archive Data within the Flow Computer"* in *Volume 5* for information on the 'Archive File "n"' submenu.

2.5.20. Peer-to-Peer Communications Settings

Serial Port #2 of the flow computer can be configured to act as a simple Modbus slave port or as a peer-to-peer communication link. Using the peer-to-peer link allows multiple flow computers to be interconnected and share data.

Enter [Y] at 'Peer / Peer Comm (Y) ?' of the 'Misc Setup' menu to open the following submenu:

{L1} Activate Redundancy Mode

The active redundancy mode feature allows two flow computers to operate as a pair. Each flow computer receives the same process signals and performs the same calculations; i.e., in "redundancy". This mode is typically used in critical applications where failure of a flow computer cannot be tolerated.

Enter [Y] to allow both flow computers to manage the peer-to-peer link between them and automatically switch between being the master or slave computer. Important data such as meter factors and PID control settings can be continually exchanged between flow computers ensuring that at any time, should a failure occur to one, the other unit would be able to assume control of the PID and ticketing functions.

The redundancy mode requires that four digital I/O ports be cross-connected to sense watchdog failure modes using the following points 2714=Input master status, 2864=Output Master status, 2713 Input watchdog status, 2863 = Output of watchdog status. (See Technical Bulletin **TB-980402** in *Volume 5*.)

{L1} Next Master in Sequence

Enter the slave number of the next flow computer in sequence in the peer-to-peer communication sequence to pass over control. After the flow computer completes all of its transactions it will attempt to pass over master control of the Modbus link to this Modbus ID. For maximum efficiency, always start Modbus ID definitions from 1.

Enter the Modbus ID of this flow computer if there are no other peers in sequence on the communication link.

Enter [0] to disable the peer-to-peer feature and use Serial Port #2 as a standard Modbus slave port.

{L1} Last Master in Sequence ID

Enter the slave number of the last OMNI (the highest Modbus ID number) in the peer-to-peer communication sequence. This is required for error recovery. Should this flow computer be unable to hand over control to the 'next master in sequence' (see previous entry), it will attempt to establish communications with a Modbus slave with a higher Modbus ID. It will keep trying until the ID number exceeds this entry. At that point the flow computer will start at Modbus ID #1.

Enter the Modbus ID of this flow computer if it is the only master on the link.

{L1} Retry Timer

Should any slave device fail to respond to a communication request, the master device will retry to establish communications several times. Enter the number of 50 millisecond ticks that the flow computer should wait for a response from the slave device. To ensure fast recovery from communication failures, set this entry to as low a number as possible. Enter [3] for peer-to-peer links involving only OMNI flow computers. Other Modbus devices may require more time to respond.

Transaction #1

INFO - Characters in '{ }' refer to password levels. Characters in '[]' refer to key presses.

INFO - The OMNI Flow Computer determines what Modbus function code and what data type is involved by the Modbus index number of the data within the OMNI's database. The **Source Index** determines the data type for a 'write'. The **Destination Index** determines the data type for a 'read'.
Function codes used are:
01=Read Multiple Booleans
15=Write Multiple Booleans
03=Read Multiple Variables
16=Write Multiple Variables

{L1} Target Slave ID # _____

Each transfer of data is called a transaction. Enter the Modbus ID # of the other slave involved in the transaction. Modbus ID '0' can be used to broadcast write to all Modbus slave devices connected to the peer-to-peer link. Other valid IDs range from 1-247.

{L1} Read/Write ? _____

Enter **[R]** if data will be read from the slave. Enter **[W]** if data will be written to the slave.

{L1} Source Index # _____

Enter the database index number or address of the Modbus point where the data is to be obtained, corresponding to the first data point of the transaction. This is the slave's database index number when the transaction is a 'read', and the master's database index number when the transaction is a 'write'. Refer to **Volume 4** for a list of available database addresses or index numbers.

{L1} Number of Points _____

Enter the number of contiguous points to transfer. Each transaction can transfer multiple data points that can be any valid data type recognized by the OMNI. The maximum number of points that can be transferred depends on the type of data:

- 0 IEEE floats (4bytes each) → 63 max
- 0 32-bit Integers (4 bytes each) → 63 max
- 0 16-bit integers (2 bytes each) → 127 max
- 0 Packed coils or status (8 to a byte) → 2040 max.

The OMNI automatically knows what Modbus function to use and what data types are involved by the Modbus index number of the data within the flow computer database. The destination index number determines the data type when the transaction is a 'read'. The source index number determines the data type when the transaction is a 'write'.

{L1} Destination Index # _____

Enter the database index number or address of where the data is to be stored (destination index or address). If the transaction is a 'read', this will be the index number within the master OMNI's database. If the transaction is a 'write', this will be the register number within the remote slave's database.

Transaction #2

Target Slave ID # _____

Read/Write ? _____

Source Index # _____

Number of Points _____

Destination Index # _____

Transaction #3

Target Slave ID # _____

Read/Write ? _____

Source Index # _____

Number of Points _____

Destination Index # _____

TIP - Use the blank lines provided next to each configuration option to write down the corresponding settings you entered in the flow computer. Some of these entries may not appear on the display or in OmniCom. Depending on the various configuration settings of your specific metering system, only those configuration options which are applicable will be displayed.

Transaction #4

Target Slave ID # _____
Read/Write ? _____
Source Index # _____
Number of Points _____
Destination Index # _____

Transaction #5

Target Slave ID # _____
Read/Write ? _____
Source Index # _____
Number of Points _____
Destination Index # _____

Transaction #6

Target Slave ID # _____
Read/Write ? _____
Source Index # _____
Number of Points _____
Destination Index # _____

Transaction #7

Target Slave ID # _____
Read/Write ? _____
Source Index # _____
Number of Points _____
Destination Index # _____

Transaction #8

Target Slave ID # _____
Read/Write ? _____
Source Index # _____
Number of Points _____
Destination Index # _____

INFO - Characters in '{ }' refer to password levels. Characters in '[']' refer to key presses.

TIP - Use the blank lines provided next to each configuration option to write down the corresponding settings you entered in the flow computer.

Some of these entries may not appear on the display or in OmniCom. Depending on the various configuration settings of your specific metering system, only those configuration options which are applicable will be displayed.

INFO - The OMNI Flow Computer determines what Modbus function code and what data type is involved by the Modbus index number of the data within the OMNI's database. The **Source Index** determines the data type for a 'write'. The **Destination Index** determines the data type for a 'read'.

Function codes used are:
 01=Read Multiple Booleans
 15=Write Multiple Booleans
 03=Read Multiple Variables
 16=Write Multiple Variables

Transaction #9

Target Slave ID # _____

Read/Write ? _____

Source Index # _____

Number of Points _____

Destination Index # _____

Transaction #10

Target Slave ID # _____

Read/Write ? _____

Source Index # _____

Number of Points _____

Destination Index # _____

Transaction #11

Target Slave ID # _____

Read/Write ? _____

Source Index # _____

Number of Points _____

Destination Index # _____

Transaction #12

Target Slave ID # _____

Read/Write ? _____

Source Index # _____

Number of Points _____

Destination Index # _____

Transaction #13

Target Slave ID # _____

Read/Write ? _____

Source Index # _____

Number of Points _____

Destination Index # _____

TIP - Use the blank lines provided next to each configuration option to write down the corresponding settings you entered in the flow computer. Some of these entries may not appear on the display or in OmniCom. Depending on the various configuration settings of your specific metering system, only those configuration options which are applicable will be displayed.

Transaction #14

Target Slave ID # _____

Read/Write ? _____

Source Index # _____

Number of Points _____

Destination Index # _____

Transaction #15

Target Slave ID # _____

Read/Write ? _____

Source Index # _____

Number of Points _____

Destination Index # _____

Transaction #16

Target Slave ID # _____

Read/Write ? _____

Source Index # _____

Number of Points _____

Destination Index # _____

2.6. Setting Up the Time and Date

INFO - The first menu, 'Misc Configuration', should always be completed first as these entries specify the number and type of input and output devices connected to the flow computer; i.e., the menus following the 'Misc Configuration' menu do not ask for configuration data unless a transducer has been defined.

Flow Computer Configuration via the Menu Selection Method - It is best to use this method when programming an application for the first time as every possible option and variable will be prompted. Once a computer is in operation and you become familiar with the application you can decide to use the faster Random Access Method described below. Once you have finished entering data in a setup submenu, press the **[Prog]** key to return to the 'Select Group Entry' screen. Proceed as described in this manual for each setup option.

Time and Date Setup via the Random Access Method - Setup entries require that you be in the Program Mode. In the Display Mode press the **[Prog]** key. The Program LED will glow *green* and the 'Select Group Entry' screen will appear. Then press **[Time] [Enter]** and use **[↑] / [↓]** keys to scroll.

2.6.1. Accessing the Time/Date Setup Submenu

Applying the Menu Selection Method (see sidebar), in the 'Select Group Entry' screen (Program Mode) press **[Setup] [Enter]** and a menu similar to the following will be displayed:

```

***  SETUP MENU  ***
Misc Configuration
Time/Date Setup  _
Station Setup
    
```

Use the **[↑]/[↓]** (up/down arrow) keys to move the cursor to 'Time/Date Setup' and press **[Enter]** to access the submenu.

2.6.2. Time and Date Settings

{L1} OMNI Time _____:_____:_____

Enter Current Time using the correct method 'hh:mm:ss'. To change only the hour, minutes or seconds, move cursor to the respective position and enter the new setting.

{L1} OMNI Date _____/_____/_____

Enter Current Date using the correct method 'mm/dd/yy' or 'dd/mm/yy'. To change only the month, day or year, move cursor to the respective position and enter the new setting.

{L1} Select Date Format Type _____

Select date format required by entering **[Y]** or **[N]**:

- Y = month/day/year
- N = day/month/year

2.7. Configuring the Meter Station

Meter Station Setup via the Random Access Method - Setup entries require that you be in the Program Mode. In the Display Mode press the [Prog] key. The Program LED will glow *green* and 'Select Group Entry' screen will appear. Then press [Meter] [Enter] and use [↑] / [↓] keys to scroll.

Meter Station Run Switching Flow Rate Thresholds - The OMNI flow computer has 3 Boolean flags which are set or reset depending on the station flow rate:

- 0 Run Switching Flag #1 at Modbus database point **1824**.
- 0 Run Switching Flag #2 at Modbus database point **1825**.
- 0 Run Switching Flag #3 at Modbus database point **1826**.

Each of these flags has a low threshold and high threshold flow rate. Each flag is set when the station flow rate exceeds the corresponding high threshold value. These flags reset when the station flow rate falls below the respective low threshold limit.

See **Chapter 3** for more information on how to include these flags in Boolean statements to automatically switch meter runs depending on flow rates.

2.7.1. Accessing the Station Setup Submenu

Applying the Menu Selection Method (see sidebar), in the 'Select Group Entry' screen (Program Mode) press [Setup] [Enter] and a menu similar to the following will be displayed:

```
***  SETUP MENU  ***
Misc Configuration
Time/Date Setup
Station Setup  _
```

Use the [↑]/[↓] (up/down arrow) keys to move the cursor to 'Station Setup' and press [Enter] to access the submenu.

2.7.2. Meter Station Settings

{L1} Station ID _____

Enter 8 alphanumeric characters maximum. This string variable usually appears in user custom reports (Modbus database point **4815**).

Flow Low Alarm Limit _____

Enter the flow rate below which the Station Low Flow Alarm activates (Modbus database point **1810**). Flow rates 5% below this value activate the Low Low Alarm (Modbus database point **1809**).

Flow High Alarm Limit _____

Enter the flow rate above which the Station High Flow Alarm activates (Modbus database point **1811**). Flow rates 5% above this value activate the High High Alarm (Modbus database point **1812**).

{L1} Gross Flow Rate at Full Scale _____

Enter the gross flow rate at full scale for the meter station. Sixteen-bit integer variables representing station gross and net flow rate are included in the database at **3802** and **3804**. These variables are scaled using this entry and stored as percentage of full scale with a resolution of 0.1% (i.e., 0 to 999 = 0% to 99.9%)

{L1} Mass Flow Rate at Full Scale _____

Enter the mass flow rate at full scale for the meter station. A 16-bit integer variable representing station mass flow rate is included in the database at **3806**. This variable is scaled using this entry and stored as percentage of full scale with a resolution of 0.1% (i.e., 0 to 1000 = 0% to 100.0%)

Flag #1 Flag #2 Flag #3

{L1} Run Switching Threshold Low _____

Enter the flow rate Low Threshold value which resets each Station Run Switching Flag when the station gross flow rate falls below this limit (see sidebar).

{L1} Run Switching Threshold High _____

Enter the flow rate High Threshold value which sets each Station Run Switching Flag when the station gross flow rate exceeds this limit (see sidebar).

INFO - Characters in '{ }' refer to password levels. Characters in '[]' refer to key presses.

TIP - Use the blank lines provided next to each configuration option to write down the corresponding settings you entered in the flow computer.

Some of these entries may not appear on the display or in OmniCom. Depending on the various configuration settings of your specific metering system, only those configuration options which are applicable will be displayed.

INFO - See the previous chapter for a description of batching features of the OMNI flow computer.

{L1} Use Common Batch Stack? _____

Enter [Y] to set up the flow computer to use a common product on all four meter runs; i.e., to run the same product at the same time on all 4 meter runs. Enter [N] to run different products at the same time on each meter run. (See **Volume 2b** on Batching Operations.)

{L1} Batch Preset Warning _____

Enter the quantity of barrels for the Batch Preset Warning. This entry displays only when Common Batch Stack is selected. The Batch preset counters are activated when a non-zero number is entered for batch size on the batch sequence stack (see **Volume 2b** on Batching Operations). The batch preset reached flag (database point **1819**) will be activated whenever the batch preset counter counts down to zero. The batch warning flag (database point **1818**) will be activated when the batch preset counter is equal or less than this entry.

{L1} Relative Density (Gravity) / Density Rate of Change _____

This entry displays only when a Station Density I/O Point has been assigned. It is used to detect product changes in the pipeline (product interface).

Enter the Gravity or Density Rate of Change in relative density units per barrel (US units) or in Kgs/m³ per cubic meter (metric units) for this limit. The Relative Density/Density Rate of Change Flag (database point **1813**) is activated if the flowing gravity/density measured by the station densitometer exceeds this preset rate of change.

{L1} Line Pack Delay _____

This entry displays only when a Station Density I/O Point has been assigned. In many cases, the station densitometer that detects the product interfaces is installed many net barrels in advance of the metering skid to provide prior warning of a product change.

Enter the Line Pack Delay as the quantity of net barrels or net m³ between the product interface detector densitometer or gravitometer and the valve manifold used to end the batch. A Delayed Gravity Rate of Change Flag (database point **1814**) is set when this number of barrels or m³ has been measured after the Product Interface Flag (database point **1813**) is activated; i.e., a line pack delay is counted down to zero when a product interface is detected.

{L1} Relative Density (Specific Gravity) Sample Time _____

This entry displays only when a Station Density I/O Point has been assigned. It is used with the previous entry to determine the relative density rate of change.

Estimate the minimum amount of time in seconds it takes for a product change to be complete and set this timer by entering approximately 1/4 to 1/3 of that time. False triggering of the product interface detection flag can be eliminated by ensuring that any density change must exist for at least this many seconds.

{L1} Gross Batch Preset Counter Units? _____

Enter [Y] to select gross (actual) volume units (IV). Enter [N] to select net volume units (GSV).

{PL} Select Volume Units _____

This entry corresponds to metric units only and applies globally to all volumes within the flow computer. Enter the volume units:

- 0 = Cubic meters (m³)
- 1 = Liters (lts)

Prove Report **Batch Report**

{PL} Number of Decimal Places for Factors _____

Enter the number of decimal places to use for correction factors appearing on prove and batch reports (4, 5 or 6 decimal places). These settings correspond to the following factors: CTLM, CTLP, CPLM, CPLP, CTSP, CPSP, CCF.

The density pycnometer factor remains fixed at four decimal places. For strict adherence to API MPMS 12.2 (default) select 4 decimal places. This is the recommend selection. Selecting 5 decimal places causes the flow computer to perform the normal API internal rounding and truncating rules with the exception of the last round which is to 5 places. Selecting 6 decimal places causes the flow computer to perform no internal rounding and truncating and rounds the final result to 6 decimal places.

Auxiliary Input Setup via the Random Access Method - Setup entries require that you be in the Program Mode. In the Display Mode press the [Prog] key. The Program LED will glow green and 'Select Group Entry' screen will appear. Then press [Analysis] [Input] [Enter] or [Analysis] [Input] [n] [Enter] (n = Auxiliary Input # 1, 2, 3 or 4). Use [↑] / [↓] keys to scroll.

Note:
* Not Valid when a RTD Probe is specified.

Auxiliary Inputs

Input #1 Input #2 Input #3 Input#4

Low Alarm Limits _____

Enter the auxiliary input signal value below which the Low Alarm activates. The low low alarm activates when the auxiliary Input signal falls 5% below this value.

High Alarm Limits _____

Enter the auxiliary input signal value above which the High Alarm activates. The high high alarm will activate when the auxiliary Input signal rises 5% above this value.

{L2} Override Values _____

Enter the value (in engineering units) which will be substituted for the transducer value, depending on the override code selected. An '**' displayed along side of the value indicates that the override value is substituted.

{L2} Override Codes _____

Enter the Override Code which represents the strategy used regarding each auxiliary input override value:

- 0 = Never use override value
- 1 = Always use override value
- 2 = On transmitter failure, use override value
- 3 = On transmitter failure, use last hour's average

{L1} at 4mA* _____

Enter the value in engineering units that produces a transducer output of 4mA or 1volt, or the 'lower range limit' (LRV) of Honeywell™ Smart Transmitters.

{L1} at 20mA* _____

Enter the value in engineering units that produces a transducer output of 20mA or 5 Volts, or 'upper range limit' (URV) of Honeywell™ Smart Transmitters.

{L1} Damping Code _____

This entry only applies to Honeywell digital transmitters connected to an 'H' type combo module. The process variable (i.e., temperature/pressure) is filtered by the transmitter before being sent to the flow computer. The time constant used depends on this entry.

For Pressure Transmitters, enter the selected Damping Code:

- | | |
|------------------|----------------|
| 0 = 0 seconds | 5 = 2 seconds |
| 1 = 0.16 seconds | 6 = 4 seconds |
| 2 = 0.32 seconds | 7 = 8 seconds |
| 3 = 0.48 seconds | 8 = 16 seconds |
| 4 = 1 seconds | 9 = 32 seconds |

For Temperature Transmitters, enter the selected Damping Code:

- | | |
|-----------------|-------------------|
| 0 = 0 seconds | 5 = 6.3 seconds |
| 1 = 0.3 seconds | 6 = 12.7 seconds |
| 2 = 0.7 seconds | 7 = 25.5 seconds |
| 3 = 1.5 seconds | 8 = 51.5 seconds |
| 4 = 3.1 seconds | 9 = 102.5 seconds |

2.8. Configuring Meter Runs

INFO - The first menu, 'Misc Configuration', should always be completed first as these entries specify the number and type of input and output devices connected to the flow computer; i.e., the menus following the 'Misc Configuration' menu do not ask for configuration data unless a transducer has been defined.

Flow Computer Configuration via the Menu Selection Method - It is best to use this method when programming an application for the first time as every possible option and variable will be prompted. Once a computer is in operation and you become familiar with the application you can decide to use the faster Random Access Method described below. Once you have finished entering data in a setup submenu, press the **[Prog]** key to return to the 'Select Group Entry' screen. Proceed as described in this manual for each setup option.

Meter Run Setup via the Random Access Method - Setup entries require that you be in the Program Mode. In the Display Mode press the **[Prog]** key. The Program LED will glow green and the 'Select Group Entry' screen will appear. Then press **[Meter#]** **[Enter]** (*n = Meter Run # 1, 2, 3 or 4*). Use **[↑]** / **[↓]** keys to scroll.

Alternate Access to Meter Run Settings from Meter Station Setup - After entering the Meter Station Settings, without exiting, press the **[↓]** key and you will scroll down through each Meter Run setup entry.

2.8.1. Accessing the Meter Run Setup Submenu

Applying the Menu Selection Method (see sidebar), in the 'Select Group Entry' screen (Program Mode) press **[Setup]** **[Enter]** and a menu similar to the following will be displayed:

```

***  SETUP MENU  ***
Time/Date Setup
Station Setup
Meter Run Setup  _
    
```

Use the **[↑]**/**[↓]** (up/down arrow) keys to move the cursor to 'Meter Run Setup' and press **[Enter]** to access the submenu.

2.8.2. Meter Run Settings

- | | <u>Meter #1</u> | <u>Meter #2</u> | <u>Meter #3</u> | <u>Meter #4</u> |
|---|-----------------|-----------------|-----------------|-----------------|
| {L1} Meter ID _____ | | | | |
| Enter the ID of the flowmeter (up to 8 alphanumeric characters) for each meter run. This ID usually appears on reports. | | | | |
| Flow Low Alarm Limit _____ | | | | |
| Enter the flow rate for each meter run below which the Flow Low Alarm (database point 1n21) activates. The Low Low Alarm (database point 1n20) activates when the flow rate falls 5% below this limit. | | | | |
| Flow High Alarm Limit _____ | | | | |
| Enter the flow rate for each meter run above which the Flow High Alarm (database point 1n22) activates. The High High Alarm (database point 1n23) activates when the flow rate rises 5% above this limit. | | | | |
| {L1} Gross Flow Rate at Full Scale _____ | | | | |
| Enter the gross flow rate at full-scale for each meter run. Sixteen-bit integer variables representing meter run gross and net flow rate are included in the database at 3n42 and 3n40 respectively. These variables are scaled using this entry and stored as percentage of full scale with a resolution of 0.1% (i.e., 0 to 1000 = 0% to 100.0%) | | | | |
| {L1} Mass Flow Rate at Full Scale _____ | | | | |
| Enter the mass flow rate at full-scale for each meter run. A 16-bit integer variable representing meter run mass flow rate is included in the database at 3n44 . This variable is scaled using this entry and stored as percentage of full scale with a resolution of 0.1% (i.e., 0 to 1000 = 0% to 100.0%) | | | | |
| {L1} Active Frequency Threshold _____ | | | | |
| Enter the Active Frequency Threshold for each meter run. Flow meter pulse frequencies equal or greater than this threshold will cause the Meter Active Flag (1n05) to be set.
By using any Boolean statement you can use this flag bit to enable and disable totalizing by controlling the Disable Meter Run Totalizer Flags (Modbus database points 1736 , 1737 , 1738 & 1739).
Example: 1030 1736=/1105 ⇒ Turn off Meter #1 flow if not greater than Active Frequency. | | | | |

INFO - Characters in '{ }' refer to password levels. Characters in '[]' refer to key presses.

TIP - Use the blank lines provided next to each configuration option to write down the corresponding settings you entered in the flow computer. Some of these entries may not appear on the display or in OmniCom. Depending on the various configuration settings of your specific metering system, only those configuration options which are applicable will be displayed.

Meter #1 Meter #2 Meter #3 Meter #4

{L1} Error Check Threshold _____

This entry will display only when 'Dual Pulse' is selected under 'Config Meter Runs' (Misc Setup). It applies only when a 'E' combo module is fitted and 'Pulse Fidelity Checking' is enabled.

Enter the Pulse Fidelity Error Check Threshold (in Hz) for each meter run. To eliminate bogus alarms and error count accumulations, the dual pulse error checking functions are disabled until the sum of both pulse trains exceeds the pulses per seconds entered for this setting.

Example: Entering 50 for this threshold means that the dual pulse error checking will be disabled until both A and B channels of the flowmeter pick-offs are providing 25 pulses per second each.

{L1} Max Error Counts per Batch _____

This entry will display only when 'Dual Pulse' is selected under 'Config Meter Runs' (Misc Setup). It applies only when a 'E' combo module is fitted and 'Pulse Fidelity Checking' is enabled.

Enter the maximum number of error pulses allowed in one transaction for each meter run. The alarm points are:

- 0 1n48 A/B Comparator Error Detected
- 0 1n49 A Channel Failed
- 0 1n50 B Channel Failed
- 0 1n51 A and B Channels not equal

The dual pulse A/B Comparator Error Alarm (**1n48**) is activated when the accumulated error counts between the flowmeter channels exceeds this count threshold. Accumulated error counts are cleared for every batch.

{L1A} Meter K-Factor _____

Enter the number of pulses per unit volume that the flowmeter produces; i.e., pulses/barrel (US units), or pulses/m³ or pulses/liter (metric units). The K factor is used to calculate the gross flow rate.

{L1} Prove Base Flow Rate _____

Enter the base prove flow rate. This should be the normal flow rate of the flowmeter. For comparison and historical averaging purposes, the flow computer will normalize all meter factors to this flow rate using the base meter factor curve entered in the 'Product Setup' submenu (see 'Configuring Products' this chapter).

{L1} Upstream Prover Volume? _____

This entry displays only when the prover type selected is a Uni-Compact (see 'Configuring Provers' in this chapter). Enter [Y] to select upstream volume as the prove volume. Enter [N] to select downstream volume as the prove volume.

Certain models of compact provers (such as the Brooks compact prover) have different water draw volumes depending on whether the flowmeter is upstream or downstream of the prover. This entry has no meaning when you are using a normal full-sized prover with one water draw volume.

{L1} Use Meter Factor in Net? (Y) _____

Enter [Y] to apply the meter factor in the net and mass flow equations. Enter [N] to ignore the meter factor in flow calculations; nonetheless, it will still appear on all reports.

{L1} Temperature Compensated? _____

In some cases, the flowmeter may be fitted with a mechanical or electronic temperature compensator. Enter [Y] for the OMNI Flow Computer to set the temperature correction (VCF) to 1.0000 in all equations. Enter [N] if the meter provides gross uncompensated pulses.

2.9. Configuring Temperature

INFO - The first menu, 'Misc Configuration', should always be completed first as these entries specify the number and type of input and output devices connected to the flow computer; i.e., the menus following the 'Misc Configuration' menu do not ask for configuration data unless a transducer has been defined.

Flow Computer Configuration via the Menu Selection Method - It is best to use this method when programming an application for the first time as every possible option and variable will be prompted. Once a computer is in operation and you become familiar with the application you can decide to use the faster Random Access Method described below. Once you have finished entering data in a setup submenu, press the [Prog] key to return to the 'Select Group Entry' screen. Proceed as described in this manual for each setup option.

Meter Temperature Setup via the Random Access Method - Setup entries require that you be in the Program Mode. In the Display Mode press the [Prog] key. The Program LED will glow green and the 'Select Group Entry' screen will appear. Then press [Temp] [Enter], or [Temp] [Meter] [n] [Enter] or [Meter] [n] [Temp] [Enter] (n = Meter Run # 1, 2, 3 or 4). Use [↑] / [↓] keys to scroll.

Note:
* Not Valid when a RTD Probe is specified.

2.9.1. Accessing the Temperature Setup Submenu

Applying the Menu Selection Method (see sidebar), in the 'Select Group Entry' screen (Program Mode) press [Setup] [Enter] and a menu similar to the following will be displayed:

```

***  SETUP MENU  ***
Station Setup
Meter Run Setup
Temperature Setup _
    
```

Use the [↑]/[↓] (up/down arrow) keys to move the cursor to 'Temperature Setup' and press [Enter] to access the submenu.

2.9.2. Station and Meter Run Temperature Settings

- | | <u>Station</u> | <u>Meter #1</u> | <u>Meter #2</u> | <u>Meter #3</u> | <u>Meter #4</u> |
|---|----------------|-----------------|-----------------|-----------------|-----------------|
| Low Alarm Limit | _____ | _____ | _____ | _____ | _____ |
| Enter the temperature below which the flowmeter low alarm activates. Transducer values approximately 5% below this entry fail to low. | | | | | |
| High Alarm Limit | _____ | _____ | _____ | _____ | _____ |
| Enter the temperature above which the flowmeter high alarm activates. Transducer values approximately 5% above this entry fail to high. | | | | | |
| {L2} Override | _____ | _____ | _____ | _____ | _____ |
| Enter the temperature value that is substituted for the live transducer value, depending on the override code. An "*" displayed along side of the value indicates that the override value is substituted. | | | | | |
| {L2} Override Code | _____ | _____ | _____ | _____ | _____ |
| Enter the Override Code strategy: | | | | | |
| 0 = Never use override code | | | | | |
| 1 = Always use override code | | | | | |
| 2 = Use override code on transmitter failure | | | | | |
| 3 = On transmitter failures use last hour's average | | | | | |
| {L1} at 4mA* | _____ | _____ | _____ | _____ | _____ |
| Enter the temperature engineering units that the transmitter outputs at 4mA or 1volt, or lower range limit (LRV) of Honeywell Smart Transmitters. | | | | | |
| {L1} at 20mA* | _____ | _____ | _____ | _____ | _____ |
| Enter the temperature engineering units that the transmitter outputs at 20mA or 5 Volts, or upper range limit (URV) of Honeywell Smart Transmitters. | | | | | |

INFO - Characters in '{ }' refer to password levels. Characters in '[]' refer to key presses.

TIP - Use the blank lines provided next to each configuration option to write down the corresponding settings you entered in the flow computer. Some of these entries may not appear on the display or in OmniCom. Depending on the various configuration settings of your specific metering system, only those configuration options which are applicable will be displayed.

Meter Density Temperature Setup via the Random Access Method - To access these settings, in the Program Mode press [Density] [Temp] [Enter].

INFO - The Density Temperature sensor is used to compensate for temperature expansion effects which effect the periodic time of oscillation of the densitometer. It is also used when desired to calculate the density of the liquid to reference temperature using API 2540; Table 23, 23A or 23B.

Note:
* Not Valid when a RTD Probe is specified.

Station Meter #1 Meter #2 Meter #3 Meter #4

{L1} Damping Code _____

This entry only applies to Honeywell digital transmitters connected to an H Type combo module. The process variable (i.e., temperature) is filtered by the transmitter before being sent to the flow computer. The time constant used depends on this entry.

For Temperature Transmitters, enter the selected Damping Code:

- 0 = 0 seconds 5 = 6.3 seconds
- 1 = 0.3 seconds 6 = 12.7 seconds
- 2 = 0.7 seconds 7 = 25.5 seconds
- 3 = 1.5 seconds 8 = 51.5 seconds
- 4 = 3.1 seconds 9 = 102.5 seconds

2.9.3. Station and Meter Run Density Temperature Settings

Station Meter #1 Meter #2 Meter #3 Meter #4

Low Limit _____

Enter the temperature below which the densitometer low alarm activates. Transducer values approximately 5% below this entry activate the transducer fail low alarm.

High Limit _____

Enter the temperature above which the densitometer high alarm activates. Transducer values approximately 10% above this entry activate the transducer fail high alarm.

{L2} Override _____

Enter the temperature value that is substituted for the live transducer value, depending on the override code. An "*" displayed along side of the value indicates that the override value is substituted.

{L2} Override Code _____

Enter the Override Code strategy:

- 0 = Never use override code
- 1 = Always use override code
- 2 = Use override code on transmitter failure
- 3 = On transmitter failures use last hour's average

{L1} at 4mA* _____

Enter the temperature engineering units that the transducer outputs at 4mA or 1volt, or lower range limit (LRV) of Honeywell Smart Transmitters.

{L1} at 20mA* _____

Enter the temperature engineering units that the transducer outputs at 20mA or 5volts, or upper range limit (URV) of Honeywell Smart Transmitters.

{L1} Damping Code _____

This entry only applies to Honeywell digital transmitters connected to an H Type combo module. The process variable (i.e., temperature) is filtered by the transmitter before being sent to the flow computer. The time constant used depends on this entry.

For Temperature Transmitters, enter the selected Damping Code:

- 0 = 0 seconds 5 = 6.3 seconds
- 1 = 0.3 seconds 6 = 12.7 seconds
- 2 = 0.7 seconds 7 = 25.5 seconds
- 3 = 1.5 seconds 8 = 51.5 seconds
- 4 = 3.1 seconds 9 = 102.5 seconds

2.9.4. Prover Temperature Settings

Prover Temperature Setup via the Random Access Method - Setup entries require that you be in the Program Mode. In the Display Mode press the **[Prog]** key. The Program LED will glow *green* and the 'Select Group Entry' screen will appear. Then press **[Prove] [Temp] [Enter]** or **[Temp] [Prove] [Enter]**. Use **[↑] / [↓]** keys to scroll.

	<u>Inlet</u>	<u>Outlet</u>
Low Alarm Limit	_____	_____
Enter the temperature below which the prover low alarm activates. Transducer values approximately 5% below this entry activate the transducer fail low alarm.		
High Alarm Limit	_____	_____
Enter the temperature above which the prover high alarm activates. Transducer values approximately 10% above this entry activate the transducer fail high alarm.		
{L2} Override	_____	_____
Enter the temperature value that is substituted for the live transducer value, depending on the override code. An "*" displayed along side of the value indicates that the override value is substituted.		
{L2} Override Code	_____	_____
Enter the Override Code strategy:		
0 = Never use override code		
1 = Always use override code		
2 = Use override code on transmitter failure		
3 = On transmitter failures use last hour's average		
{L1} @ 4mA*	_____	_____
Enter the temperature engineering units that the transducer outputs at 4mA or 1volt, or lower range limit (LRV) of Honeywell Smart Transmitters.		
{L1} @ 20mA*	_____	_____
Enter the temperature engineering units that the transducer outputs at 20mA or 5volts, or upper range limit (URV) of Honeywell Smart Transmitters.		
{L1} Damping Code	_____	_____
This entry only applies to Honeywell digital transmitters connected to an H Type combo module. The process variable (i.e., temperature) is filtered by the transmitter before being sent to the flow computer. The time constant used depends on this entry.		
For Temperature Transmitters, enter the selected Damping Code:		
0 = 0 seconds 5 = 6.3 seconds		
1 = 0.3 seconds 6 = 12.7 seconds		
2 = 0.7 seconds 7 = 25.5 seconds		
3 = 1.5 seconds 8 = 51.5 seconds		
4 = 3.1 seconds 9 = 102.5 seconds		

2.9.5. Prover Density Temperature Settings

INFO - Characters in '{ }' refer to password levels.

TIP - Use the blank lines provided next to each configuration option to write down the corresponding settings you entered in the flow computer.

	<u>Inlet</u>	<u>Outlet</u>
Low Alarm Limit	_____	_____
Enter the temperature below which the prover low alarm activates. Transducer values approximately 5% below this entry activate the transducer fail low alarm.		
High Alarm Limit	_____	_____
Enter the temperature above which the prover high alarm activates. Transducer values approximately 10% above this entry activate the transducer fail high alarm.		
{L2} Override	_____	_____
Enter the temperature value that is substituted for the live transducer value, depending on the override code. An "*" displayed along side of the value indicates that the override value is substituted.		
{L2} Override Code	_____	_____
Enter the Override Code strategy:		
0 = Never use override code		
1 = Always use override code		
2 = Use override code on transmitter failure		
3 = On transmitter failures use last hour's average		
{L1} at 4mA*	_____	_____
Enter the temperature engineering units that the transducer outputs at 4mA or 1volt, or lower range limit (LRV) of Honeywell Smart Transmitters.		
{L1} at 20mA*	_____	_____
Enter the temperature engineering units that the transducer outputs at 20mA or 5volts, or upper range limit) URV of Honeywell Smart Transmitters.		
{L1} Damping Code	_____	_____
This entry only applies to Honeywell digital transmitters connected to an H Type combo module. The process variable (i.e., temperature) is filtered by the transmitter before being sent to the flow computer. The time constant used depends on this entry.		
For Temperature Transmitters, enter the selected Damping Code:		
0 = 0 seconds 5 = 6.3 seconds		
1 = 0.3 seconds 6 = 12.7 seconds		
2 = 0.7 seconds 7 = 25.5 seconds		
3 = 1.5 seconds 8 = 51.5 seconds		
4 = 3.1 seconds 9 = 102.5 seconds		

2.10. Configuring Pressure

INFO - The first menu, 'Misc Configuration', should always be completed first as these entries specify the number and type of input and output devices connected to the flow computer; i.e., the menus following the 'Misc Configuration' menu do not ask for configuration data unless a transducer has been defined.

Flow Computer Configuration via the Menu Selection Method - It is best to use this method when programming an application for the first time as every possible option and variable will be prompted. Once a computer is in operation and you become familiar with the application you can decide to use the faster Random Access Method described below. Once you have finished entering data in a setup submenu, press the **[Prog]** key to return to the 'Select Group Entry' screen. Proceed as described in this manual for each setup option.

Meter Pressure Setup via the Random Access Method - Setup entries require that you be in the Program Mode. In the Display Mode press the **[Prog]** key. The Program LED will glow *green* and the 'Select Group Entry' screen will appear. Then press **[Press] [Enter]**, or **[Press] [Meter] [n] [Enter]** or **[Meter] [n] [Press] [Enter]** (*n* = Meter Run # 1, 2, 3 or 4). Use **[↑]** / **[↓]** keys to scroll.

2.10.1. Accessing the Pressure Setup Submenu

Applying the Menu Selection Method (see sidebar), in the 'Select Group Entry' screen (Program Mode) press **[Setup] [Enter]** and a menu similar to the following will be displayed:

```

***  SETUP MENU  ***
Meter Run Setup
Temperature Setup
Pressure Setup  _
    
```

Use the **[↑]**/**[↓]** (up/down arrow) keys to move the cursor to 'Pressure Setup' and press **[Enter]** to access the submenu.

2.10.2. Station and Meter Run Pressure Settings

- | | <u>Station</u> | <u>Meter #1</u> | <u>Meter #2</u> | <u>Meter #3</u> | <u>Meter #4</u> |
|--|----------------|-----------------|-----------------|-----------------|-----------------|
| Low Alarm Limit | _____ | _____ | _____ | _____ | _____ |
| Enter the pressure below which the flowmeter low alarm activates. Transducer values approximately 5% below this entry fail to low. | | | | | |
| High Alarm Limit | _____ | _____ | _____ | _____ | _____ |
| Enter the pressure above which the flowmeter high alarm activates. Transducer values approximately 10% above this entry fail to high. | | | | | |
| {L2} Override | _____ | _____ | _____ | _____ | _____ |
| Enter the pressure value that is substituted for the live transducer value, depending on the override code. An "*" displayed along side of the value indicates that the override value is substituted. | | | | | |
| {L2} Override Code | _____ | _____ | _____ | _____ | _____ |
| Enter the Override Code strategy: | | | | | |
| 0 = Never use override code | | | | | |
| 1 = Always use override code | | | | | |
| 2 = Use override code on transmitter failure | | | | | |
| 3 = On transmitter failures use last hour's average | | | | | |
| {L1} at 4mA* | _____ | _____ | _____ | _____ | _____ |
| Enter the pressure engineering units that the transmitter outputs at 4mA or 1volt, or lower range limit (LRV) of Honeywell Smart Transmitters. | | | | | |
| {L1} at 20mA* | _____ | _____ | _____ | _____ | _____ |
| Enter the pressure engineering units that the transmitter outputs at 20mA or 5volts, or upper range limit (URV) of Honeywell Smart Transmitters. | | | | | |

INFO - Characters in '{ }' refer to password levels.

TIP - Use the blank lines provided next to each configuration option to write down the corresponding settings you entered in the flow computer.

Meter Density Pressure Setup via the Random Access Method - To access these settings, in the Program Mode press [Density] [Press] [Enter].

INFO - The Density Pressure sensor is used to compensate for pressure effects which effect the periodic time of oscillation of the densitometer. It is also used when desired to calculate the density of the liquid at the densitometer to equilibrium pressure using API 2540 MPMS 11.2.1 or 11.2.2.

Note:
* Not Valid when a RTD Probe is specified.

Station Meter #1 Meter #2 Meter #3 Meter #4

{L1} Damping Code _____

This entry only applies to Honeywell digital transmitters connected to an H Type combo module. The process variable (i.e., pressure) is filtered by the transmitter before being sent to the flow computer. The time constant used depends on this entry.

For Pressure Transmitters, enter the selected Damping Code:

- | | |
|------------------|----------------|
| 0 = 0 seconds | 5 = 2 seconds |
| 1 = 0.16 seconds | 6 = 4 seconds |
| 2 = 0.32 seconds | 7 = 8 seconds |
| 3 = 0.48 seconds | 8 = 16 seconds |
| 4 = 1 seconds | 9 = 32 seconds |

2.10.3. Station and Meter Run Density Pressure Settings

Station Meter #1 Meter #2 Meter #3 Meter #4

Low Alarm Limit _____

Enter the pressure below which the densitometer low alarm activates. Transducer values approximately 5% below this entry activate the transducer fail low alarm.

High Alarm Limit _____

Enter the pressure above which the densitometer high alarm activates. Transducer values approximately 10% above this entry activate the transducer fail high alarm.

{L2} Override _____

Enter the pressure value that is substituted for the live transducer value, depending on the override code. An "*" displayed along side of the value indicates that the override value is substituted.

{L2} Override Code _____

Enter the Override Code strategy:

- 0 = Never use override code
- 1 = Always use override code
- 2 = Use override code on transmitter failure
- 3 = On transmitter failures use last hour's average

{L1} at 4mA* _____

Enter the pressure engineering units that the transducer outputs at 4mA or 1volt, or lower range limit (LRV) of Honeywell Smart Transmitters.

{L1} at 20mA* _____

Enter the pressure engineering units that the transducer outputs at 20mA or 5volts, or upper range limit (URV) of Honeywell Smart Transmitters.

{L1} Damping Code _____

This entry only applies to Honeywell digital transmitters connected to an H Type combo module. The process variable (i.e., pressure) is filtered by the transmitter before being sent to the flow computer. The time constant used depends on this entry.

For Pressure Transmitters, enter the selected Damping Code:

- | | |
|------------------|----------------|
| 0 = 0 seconds | 5 = 2 seconds |
| 1 = 0.16 seconds | 6 = 4 seconds |
| 2 = 0.32 seconds | 7 = 8 seconds |
| 3 = 0.48 seconds | 8 = 16 seconds |
| 4 = 1 seconds | 9 = 32 seconds |

Prover Pressure Setup via the Random Access Method - Setup entries require that you be in the Program Mode. In the Display Mode press the [Prog] key. The Program LED will glow *green* and the 'Select Group Entry' screen will appear. Then press [Prove] [Press] [Enter] or [Press] [Prove] [Enter].

2.10.4. Prover Pressure Settings

	<u>Inlet</u>	<u>Outlet</u>
Low Alarm Limit	_____	_____
Enter the pressure below which the prover low alarm activates. Transducer values approximately 5% below this entry activate the transducer fail low alarm.		
High Alarm Limit	_____	_____
Enter the pressure above which the prover high alarm activates. Transducer values approximately 10% above this entry activate the transducer fail high alarm.		
{L2} Override	_____	_____
Enter the pressure value that is substituted for the live transducer value, depending on the override code. An "*" displayed along side of the value indicates that the override value is substituted.		
{L2} Override Code	_____	_____
Enter the Override Code strategy:		
0 = Never use override code		
1 = Always use override code		
2 = Use override code on transmitter failure		
3 = On transmitter failures use last hour's average		
{L1} at 4mA	_____	_____
Enter the pressure engineering units that the transducer outputs at 4mA or 1volt, or lower range limit (LRV) of Honeywell Smart Transmitters.		
{L1} at 20mA*	_____	_____
Enter the pressure engineering units that the transducer outputs at 20mA or 5volts, or upper range limit (URV) of Honeywell Smart Transmitters.		
{L1} Damping Code	_____	_____
This entry only applies to Honeywell digital transmitters connected to an H Type combo module. The process variable (i.e., pressure) is filtered by the transmitter before being sent to the flow computer. The time constant used depends on this entry.		
For Pressure Transmitters, enter the selected Damping Code:		
0 = 0 seconds 5 = 2 seconds		
1 = 0.16 seconds 6 = 4 seconds		
2 = 0.32 seconds 7 = 8 seconds		
3 = 0.48 seconds 8 = 16 seconds		
4 = 1 seconds 9 = 32 seconds		
{L1} Plenum Pressure at 4mA	_____	_____
The plenum pressure applies only to Brooks compact provers. Enter the engineering units that the transmitter outputs at 4mA or 1volt or lower range limit (LRV) of Honeywell Smart Transmitters.		
{L1} Plenum Pressure at 20mA	_____	_____
The plenum pressure applies only to Brooks compact provers. Enter the engineering units that the transmitter outputs at 20mA or 5volts or upper range limit (URV) of Honeywell Smart Transmitters..		
{L1} Plenum Pressure Damping Code	_____	_____
This entry only applies to Honeywell digital transmitters connected to an H Type combo module. The process variable (i.e., pressure) is filtered by the transmitter before being sent to the flow computer. The time constant used depends on this entry.		
For Pressure Transmitters, enter the selected Damping Code:		
0 = 0 seconds 5 = 2 seconds		
1 = 0.16 seconds 6 = 4 seconds		
2 = 0.32 seconds 7 = 8 seconds		
3 = 0.48 seconds 8 = 16 seconds		
4 = 1 seconds 9 = 32 seconds		

2.10.5. Prover Density Pressure Settings

INFO - Characters in '{ }' refer to password levels.

TIP - Use the blank lines provided next to each configuration option to write down the corresponding settings you entered in the flow computer.

Prover Density Pressure Setup via the Random Access Method - To access these settings, in the Program Mode press [Prove] [Density] [Press] [Enter].

INFO - The Density Pressure sensor is used to compensate for pressure effects which effect the periodic time of oscillation of the densitometer. It is also used when desired to calculate the density of the liquid at the densitometer to equilibrium pressure using API 2540 MPMS 11.2.1 or 11.2.2.

Note:
* Not Valid when a RTD Probe is specified.

Inlet

Outlet

Low Alarm Limit _____

Enter the pressure below which the prover densitometer low alarm activates. Transducer values approximately 5% below this entry activate the transducer fail low alarm.

High Alarm Limit _____

Enter the pressure above which the prover densitometer high alarm activates. Transducer values approximately 10% above this entry activate the transducer fail high alarm.

{L2} Override _____

Enter the pressure value that is substituted for the live transducer value, depending on the override code. An "*" displayed along side of the value indicates that the override value is substituted.

{L2} Override Code _____

Enter the Override Code strategy:

- 0 = Never use override code
- 1 = Always use override code
- 2 = Use override code on transmitter failure
- 3 = On transmitter failures use last hour's average

{L1} at 4mA _____

Enter the pressure engineering units that the transducer outputs at 4mA or 1volt, or lower range limit (LRV) of Honeywell Smart Transmitters.

{L1} at 20mA* _____

Enter the pressure engineering units that the transducer outputs at 20mA or 5volts, or upper range limit (URV) of Honeywell Smart Transmitters.

{L1} Damping Code _____

This entry only applies to Honeywell digital transmitters connected to an H Type combo module. The process variable (i.e., pressure) is filtered by the transmitter before being sent to the flow computer. The time constant used depends on this entry.

For Pressure Transmitters, enter the selected Damping Code:

- 0 = 0 seconds
- 1 = 0.16 seconds
- 2 = 0.32 seconds
- 3 = 0.48 seconds
- 4 = 1 seconds
- 5 = 2 seconds
- 6 = 4 seconds
- 7 = 8 seconds
- 8 = 16 seconds
- 9 = 32 seconds

2.11. Configuring Meter Relative Density / API Relative Density

INFO - The first menu, 'Misc Configuration', should always be completed first as these entries specify the number and type of input and output devices connected to the flow computer; i.e., the menus following the 'Misc Configuration' menu do not ask for configuration data unless a transducer has been defined.

Flow Computer Configuration via the Menu Selection Method - It is best to use this method when programming an application for the first time as every possible option and variable will be prompted. Once a computer is in operation and you become familiar with the application you can decide to use the faster Random Access Method described below.

Once you have finished entering data in a setup submenu, press the **[Prog]** key to return to the 'Select Group Entry' screen. Proceed as described in this manual for each setup option.

2.11.1. Accessing the Gravity/Density Setup Submenu

Applying the Menu Selection Method (see sidebar), in the 'Select Group Entry' screen (Program Mode) press **[Setup] [Enter]** and a menu similar to the following will be displayed:

```
*** SETUP MENU ***
Temperature Setup
Pressure Setup
Grav/Density Setup _
```

Use the **[↑]/[↓]** (up/down arrow) keys to move the cursor to 'Grav/Density Setup' and press **[Enter]** to access the submenu.

2.11.2. Meter Relative Density / Density Settings

Relative Density, API Gravity or Density

Station Meter #1 Meter #2 Meter #3 Meter #4

{L1A} Corr Factor _____

These entries apply if an analog gravitometer or densitometer is specified during the 'Config Meter Run' in 'Misc. Setup'. They are not available when using API or Specific Gravity gravimeters. Enter the Pycnometer Density Correction Factor (Limit: 0.8 to 1.2). (Usually very close to 1.0000).

Low Alarm Limit _____

Enter the gravity/density below which the prover densitometer low alarm activates. Transducer values approximately 5% below this entry activate the transducer fail low alarm.

High Alarm Limit _____

Enter the gravity/density above which the prover densitometer high alarm activates. Transducer values approximately 10% above this entry activate the transducer fail high alarm.

{L2} Override _____

Enter the gravity/density value that is substituted for the live transducer value, depending on the override code. An '*' displayed along side of the value indicates that the override value is substituted.

{L2} Override Code _____

Enter the Override Code strategy:

- 0 = Never use override code
- 1 = Always use override code
- 2 = Use override code on transmitter failure
- 3 = On transmitter failures use last hour's average
- 4 = On transmitter failure use station transducer value
- 5 = On transmitter failure use absolute value of override SG/API of the running product.

{L1} at 4 mA _____

These entries apply if an analog gravitometer or densitometer is specified during the 'Config Meter Run' in 'Misc. Setup'. Engineering units that the transmitter outputs at 4mA or 1volt, or lower range limit (LRV) of Honeywell Smart Transmitters.

Meter Specific Gravity/Density Setup via the Random Access Method - Setup entries require that you be in the Program Mode. In the Display Mode press the [Prog] key. The Program LED will glow green and the 'Select Group Entry' screen will appear. Then enter the key press sequence that corresponds to the options you want to configure:

Specific Gravity/API:
To access these settings, press [S.G./API] [Enter] or [S.G./API] [Meter] [n] [Enter] or [Meter] [n] [S.G./API] [Enter].

Density:
To access these settings, press [Density] [Enter] or [Density] [Meter] [n] [Enter] or [Meter] [n] [Density] [Enter].

Digital Densitometers:
To access these settings, press [Factor] [Density] [Meter] [n] [Enter] or [Density] [Factor] [Meter] [n] [Enter].

("n" represents the meter run # 1, 2, 3 or 4).

Note: Digital densitometers can only be configured via the Random Access Method.

INFO - Densitometer constants are usually on a calibration certificate supplied by the densitometer manufacturer. Usually they are based on SI or metric units. For US customary applications you must ensure that the constants entered are based on gr/cc, °F and PSIG. Constants are always displayed using scientific notation; e.g.:
K₀=-1.490205E+00 (gr/cc)
To enter K₀, press [Clear] and press [-1.490205] [Alpha Shift] [E] [+00] [Enter].

Station Meter #1 Meter #2 Meter #3 Meter #4

{L1} at 20 mA _____

These entries apply if an analog gravimeter or densitometer is specified during the 'Config Meter Run' in 'Misc. Setup'. Engineering units that the transmitter outputs at 20mA or 5 Volts, or upper range limit (URV) of Honeywell Smart Transmitters.

Digital Densitometers

The following entries are required if a digital densitometer is specified during the 'Config Meter Run' in the 'Misc. Setup' menu. There are three selections which refer to digital densitometers: 4 = Solartron, 5 = Sarasota, 6 = UGC. ({L1} Password Level required, except for the Correction Factor.)

Solartron Station Meter #1 Meter #2 Meter #3 Meter #4

{L1A} Corr Factor A _____

Pycnometer Density correction factor (usually very close to 1.0000). An A and B factor are provided to cover differing products (limit: 0.8 to 1.2). Meter Station only applies Factor A.

{L1A} Corr Factor B _____

{L1} K₀ _____

{L1} K₁ _____

{L1} K₂ _____

{L1} K₁₈ _____

{L1} K₁₉ _____

{L1} K_{20A} _____

{L1} K_{20B} _____

{L1} K_{21A} _____

{L1} K_{21B} _____

{L1} K_R _____

{L1} K_J _____

Sarasota Station Meter #1 Meter #2 Meter #3 Meter #4

{L1B} Corr Factor A _____

Pycnometer Density correction factor (usually very close to 1.0000). An A and B factor are provided to cover differing products (limit: 0.8 to 1.2).

{L1B} Corr Factor B _____

{L1} D₀ _____

{L1} T₀ _____

{L1} T_{coef} _____

{L1} T_{cal} _____

{L1} P_{coef} _____

{L1} P_{cal} _____

INFO - Characters in '{ }' refer to password levels.

TIP - Use the blank lines provided next to each configuration option to write down the corresponding settings you entered in the flow computer.

Digital Densitometer Setup via the Random Access Method - To access these settings, in the Program Mode press [Factor] [Density] [Meter] [n] [Enter] or [Density] [Factor] [Meter] [n] [Enter] (n = Meter Run # 1, 2, 3 or 4).

<u>UGC</u>	<u>Station</u>	<u>Meter #1</u>	<u>Meter #2</u>	<u>Meter #3</u>	<u>Meter #4</u>
{L1A} Corr Factor A _____	_____	_____	_____	_____	_____
Pycnometer Density correction factor (usually very close to 1.0000). An A and B factor are provided to cover differing products (limit: 0.8 to 1.2).					
{L1A} Corr Factor B _____	_____	_____	_____	_____	_____
{L1} K₀ _____	_____	_____	_____	_____	_____
{L1} K₁ _____	_____	_____	_____	_____	_____
{L1} K₂ _____	_____	_____	_____	_____	_____
{L1} T_C _____	_____	_____	_____	_____	_____
{L1} K_{t1} _____	_____	_____	_____	_____	_____
{L1} K_{t2} _____	_____	_____	_____	_____	_____
{L1} K_{t3} _____	_____	_____	_____	_____	_____
{L1} P_C _____	_____	_____	_____	_____	_____
{L1} K_{p1} _____	_____	_____	_____	_____	_____
{L1} K_{p2} _____	_____	_____	_____	_____	_____
{L1} K_{p3} _____	_____	_____	_____	_____	_____

2.12. Configuring PID Control Outputs

INFO - Characters in '{ }' refer to password levels.

TIP - Use the blank lines provided next to each configuration option to write down the corresponding settings you entered in the flow computer.

Some of these entries may not appear on the display or in OmniCom. Depending on the various configuration settings of your specific metering system, only those configuration options which are applicable will be displayed.

Flow Computer Configuration via the Menu Selection Method - It is best to use this method when programming an application for the first time as every possible option and variable will be prompted. Once a computer is in operation and you become familiar with the application you can decide to use the faster Random Access Method described below. Once you have finished entering data in a setup submenu, press the [Prog] key to return to the 'Select Group Entry' screen. Proceed as described in this manual for each setup option.

PID Control Output Setup via the Random Access Method - Setup entries require that you be in the Program Mode. In the Display Mode press the [Prog] key. The Program LED will glow green and the 'Select Group Entry' screen will appear. Then press [Control] [n] [Enter] (n = PID Control Loop # 1, 2, 3 or 4). Use [↑] / [↓] keys to scroll.

2.12.1. Accessing the PID Control Setup Submenu

Applying the Menu Selection Method (see sidebar), in the 'Select Group Entry' screen (Program Mode) press [Setup] [Enter] and a menu similar to the following will be displayed:

```

***  SETUP MENU  ***
Pressure Setup
Grav/Density Setup
PID Control Setup  _
    
```

Use the [↑]/[↓] (up/down arrow) keys to move the cursor to 'PID Control Setup' and press [Enter] to access the submenu.

2.12.2. PID Control Output Settings

Loop #1 Loop #2 Loop #3 Loop #4

Operating Mode

Manual Valve Open (Y/N) _____

Enter [Y] to adjust the valve open % and adjust using the [↑]/[↓] keys. Enter [N] to change to AUTO mode.

Local Setpoint (Y/N) _____

Enter [Y] to use a local set point and adjust using the [↑]/[↓] keys. Enter [N] for 'Remote' set point mode.

Secondary Setpoint Value _____

Enter the value in engineering units for the set point of the secondary variable. The primary variable will be the controlled variable until the secondary variable reaches this set point. The secondary variable will not be allowed to drop below or rise above this set point, depending on the "Error Select" entry in the 'Config PID' menu.

Tuning Adjustments

{L1} Primary Gain Factor _____

Enter a value between 0.01 to 99.99 for the Primary Gain Factor (Gain=1/Proportional Band).

{L1} Primary Integral Factor _____

Enter a value between 0.0 and 40.00 for the Primary Integral Factor (Repeats/Min=1/Integral Factor ⇨ the reciprocal of the reset period).

{L1} Secondary Gain Factor _____

Enter a value between 0.01 to 99.99 for the Secondary Gain Factor (Gain=1/Proportional Band).

The actual controller gain factor used when controlling the secondary variable is the product of this entry and the 'Primary Gain Factor'. Tune the primary control variable first and then use this entry to adjust for stable control of the secondary variable.

{L1} Secondary Integral Factor _____

Enter a value between 0 and 40.00 for the Secondary Integral Factor (Repeats/Min=1/Integral Factor ⇨ the reciprocal of the reset period).

Loop #1 Loop #2 Loop #3 Loop #4

INFO - The first menu, 'Misc Configuration', should always be completed first as these entries specify the number and type of input and output devices connected to the flow computer; i.e., the menus following the 'Misc Configuration' menu do not ask for configuration data unless a transducer has been defined.

PID Startup, Stop and Shutdown Ramp Command Points - These have been added to eliminate the need to manipulate the PID permissives directly. Using these command points greatly simplifies operation of the PID ramping functions. (See database points **1727-1730, 1788-1791, 1792-1795** respectively.)

{L1} Deadband % _____
Enter the dead band percent range. PID Control will only compensate for setpoint deviations out of this range. The control output will not change as long as the process input and the setpoint error (deviation) is within this dead band percentage limit range.

{L1} Startup Ramp % _____
Enter the maximum percentage to which the valve movement is limited per 500 msec at start-up. The control output is clamped at 0% until the 1st PID Permissive (PID #1-#4 ⇔ database points **1722-1725**) is set true. The control output % is then allowed to increase at the start-up ramp rate.

{L1} Shutdown Ramp % _____
Enter the maximum percentage to which the valve movement is limited per 500 msec at shutdown. When the 1st PID Permissive is lost, the control output will ramp-down towards 0% at the shutdown ramp rate.

During the ramp-down phase, a 2nd PID Permissive (PID #1-#4 ⇔ database points **1752-1755**) is used to provide a "ramp hold" function. If this 2nd permissive is true, 100 msec before entering the ramp-down phase, the control output % will ramp-down and be held at the minimum ramp-down limit % (see the following entry) until it goes false. The control output will then immediately go to 0% (see sidebar).

{L1} Minimum Ramp to % _____
Enter the minimum percentage that the control output will be allowed to ramp down to. In many cases, it is important to deliver a precise amount of product. This requires that the control output be ramped to some minimum % and held there until the required delivery is complete. The control output is then immediately set to 0%.

Primary Controlled (Remote Setpoint) Variable

{L1} Low Limit _____
Enter the engineering unit value below which the primary setpoint variable is not allowed to drop while in the remote setpoint mode.

{L1} High Limit _____
Enter the engineering unit value above which the primary setpoint variable is not allowed to rise while in the remote setpoint mode.

Secondary Controlled (Setpoint) Variable

{L1} Zero Value _____
If a secondary controlled variable is used, enter the value in engineering units of the variable which will represent zero.

{L1} Full Scale Value _____
Enter the value in engineering units of the secondary variable at controller full scale, which is usually 2 times the normal operating setpoint setting.

2.13. Configuring Provers

INFO - The first menu, 'Misc Configuration', should always be completed first as these entries specify the number and type of input and output devices connected to the flow computer; i.e., the menus following the 'Misc Configuration' menu do not ask for configuration data unless a transducer has been defined.

Flow Computer Configuration via the Menu Selection Method - It is best to use this method when programming an application for the first time as every possible option and variable will be prompted. Once a computer is in operation and you become familiar with the application you can decide to use the faster Random Access Method described below.

Once you have finished entering data in a setup submenu, press the **[Prog]** key to return to the 'Select Group Entry' screen. Proceed as described in this manual for each setup option.

Prover Setup via the Random Access Method - Setup entries require that you be in the Program Mode. In the Display Mode press the **[Prog]** key. The Program LED will glow green and the 'Select Group Entry' screen will appear. Then press **[Prove]** **[Setup]** **[Enter]** and use **[↑]** / **[↓]** keys to scroll.

2.13.1. Accessing the Prover Setup Submenu

Applying the Menu Selection Method (see sidebar), in the 'Select Group Entry' screen (Program Mode) press **[Setup]** **[Enter]** and a menu similar to the following will be displayed:

```
***  SETUP MENU  ***
Grav/Density Setup
PID Cont`rol Setup
Prover Setup      _
```

Use the **[↑]**/**[↓]** (up/down arrow) keys to move the cursor to 'Prover Setup' and press **[Enter]** to access the submenu.

2.13.2. Prover Settings

{L2} Number of Runs to Average _____

Enter the number of consecutive runs required to be considered a complete prove sequence. This number must be between 2 and 10.

{L2} Maximum Number of Runs _____

Enter the maximum number of runs that will be attempted to achieve a complete prove sequence. This number must be between 2 and 99.

{L1} Prover Type _____

Enter the type of prover in use:

- 0 = Unidirectional Pipe Prover
- 1 = Bi-directional Pipe Prover
- 2 = Unidirectional Compact Prover
- 3 = Bi-directional Small Volume Prover
- 4 = Master Meter
- 5 = Two-Series Bi-directional Pipe Prover.

Select the Unidirectional Compact **[2]** if you are using a Brooks Compact Prover.

Select the Master Meter Method to compare meter 1, 2 or 3 against the master meter. Meter #4 is always the master meter.

For Double Chronometry Proving use type 2 or 3.

{L1} Prover Volume _____

This entry does not apply when the prover type selected is a Uni-Compact. Enter the water draw volume of the prover at base temperature and pressure.

Certain models of compact provers have different water draws, depending on whether the meters are upstream or downstream. This entry represents the "round-trip" volume for bi-directional provers and the downstream volume for compact provers. When using the Master Meter Method, enter the minimum volume that must flow through the master meter (Meter #4) for each prove run.

{L2} Number of Passes per Run to Average _____

This entry applies to Unidirectional and Bi-directional compact provers only. Enter the number of single passes that will be averaged to make each run when using the pulse interpolation method. Valid entries are 1 through 25. A pass is round trip when using a bi-directional prover.

INFO - Characters in '{ }' refer to password levels.

TIP - Use the blank lines provided next to each configuration option to write down the corresponding settings you entered in the flow computer.

{L1} Linear Thermal Expansion Coeff of Switch Rod _____

This entry applies to unidirectional compact provers only (except Brooks SVP —see following setting). Enter the squared coefficient of thermal expansion for any switch rod components which may affect the water draw volume of the compact prover. This Thermal Expansion Coefficient is used to calculate the CTSP factor for the compact prover:

- ∅ For US Units: Carbon Steel = 0.0000124; Stainless Steel = 0.0000177.
- ∅ For Metric Units: Carbon Steel = 0.0000223; Stainless Steel = 0.0000319.

{L1} Coefficient of Invar Rod _____

This entry applies to Brooks Compact Provers only. This prover uses an invar rod to separate the optical detector switches. The rod has a coefficient of 0.0000008 per °F (US units) or 0.0000014 per °C (metric units).

{L1} Plenum Pressure Constant _____

This entry applies to Brooks Compact Provers only. Enter the Nitrogen Spring Plenum Pressure Constant used to calculate the plenum pressure needed to operate the Brooks Compact Prover. This pressure is related to the prover line pressure at the time of proving:

$$\text{Plenum Pressure} = (\text{Line Pressure} / \text{Plenum Constant}) + 60 \text{ Psig}$$

The plenum constant depends on the size of the Brooks Compact Prover. Valid values are:

SIZE	PLENUM CONSTANT	SIZE	PLENUM CONSTANT
8-inch	3.50	18-inch	5.00
12-inch Mini	3.20	24-inch	5.88
12-inch Standard	3.20	Larger	Refer to Brooks

{L2} Plenum Pressure Deadband % _____

This entry applies to Brooks Compact Provers only. Enter the Plenum Pressure Deadband %. The Brooks Compact Prover requires that the plenum pressure be maintained within certain limits. The flow computer calculates the correct plenum pressure at the beginning of each prove sequence and will charge or vent nitrogen until the measured plenum pressure is within the specified deadband %.

{L1} Prover Upstream Volume _____

This entry applies to uni-compact provers only. Enter the upstream water draw volume at base temperature and pressure, if applicable.

{L1} Prover Downstream Volume _____

This entry applies to uni-compact provers only. Enter the downstream water draw volume at base temperature and pressure, if applicable.

{L1} Over-travel _____

This entry does not apply to Master Meter proving. Enter the estimated amount of flow that the sphere or piston displaces after activating the first detector switch, multiplied by 1.25.

{L2} Inactivity Timer _____

Enter the time in seconds before the prove is aborted due to prover inactivity. Make sure you allow enough time for the sphere or piston to travel between detector switches at the lowest flow rate expected. When using the Master Meter Method, allow enough time for the amount of flow to pass through the master meter at the lowest expected flow rate.

{L1} Prover Diameter _____

This entry is not applicable to Master Meter proving. Enter the internal diameter of the prover tube in inches or mm.

{L1} Prover Wall Thickness _____

This entry is not applicable to Master Meter proving. Enter the wall thickness of the prover tube in inches or mm, which is used to calculate the CPSP factor

Prover Setup via the Random Access Method - Setup entries require that you be in the Program Mode. In the Display Mode press the [Prog] key. The Program LED will glow green and the 'Select Group Entry' screen will appear. Then press Prove] [Setup] [Enter] and use [↑] / [↓] keys to scroll.

{L1} Modulus of Elasticity _____

This entry is not applicable to Master Meter proving. Enter the Prover Tube Modulus of Elasticity used to calculate the CPSP factor.

- 0 For US Units: Mild Steel = 3.0E7; Stainless Steel = 2.8E7 to 2.9E7.
- 0 For Metric Units: 2.07E8 or 1.93E8 to 2.0E8.

{L1} Cubical Thermal Expansion Coefficient of Tube _____

This entry is not applicable to Compact Provers and Master Meter proving. Enter the Prover Tube Cubical Coefficient of Thermal Expansion for full sized pipe provers, used to calculate the CTSP factor.

- 0 For US Units: Mild Steel = 0.0000186; Stainless Steel = 0.0000265.
- 0 For Metric Units: Mild Steel = 0.0000335; Stainless Steel = 0.0000477.

{L1} Base Pressure _____

This entry is not applicable to Master Meter proving. Enter the atmospheric pressure in PSig or kPag, at which the prover was water drawn.

{L1} Base Temperature _____

This entry is not applicable to Master Meter proving. Enter the Base Temperature in °F or °C at which the prover was water drawn. This entry is used to calculate CTSP.

{L2} Stability Check Sample Time _____

Enter the Stability Check Sample Time in seconds, used to calculate the rate of change of temperature and flow rate at the prover or master meter. The prove sequence will not start until the temperature and flow rate are stable.

{L2} Sample Time Temperature Change (ΔTemp) _____

Enter the temperature change allowed during the stability sample time (see previous entry). The change in temperature per sample period must be less than this value for the temperature to be considered stable enough to start a prove.

{L2} Sample Time Flow Rate Change (ΔFlow) _____

Enter the change in flow rate allowed during the stability sample time (see previous two entries). The change in flow rate per sample period must be less than this value before the flow rate is considered to be stable enough to start a prove.

{L2} Prover-to-Meter Temperature Deviation Range _____

Enter the prover-to-meter temperature range (°C or °F) allowable after the temperature and flow rate have stabilized. The temperature at the meter and the prover must be within this limit or the prove sequence attempt will be aborted.

{L2} Prove Run Meter Factor / Counts Repeatability _____

Enter for the run repeatability calculation based on:

- 0 = Run Counts, 1= Run Calculated Meter Factor, 2=Count, Old API, 3= Meter Factor, Old API.

Run counts repeatability is a more stringent test but may be difficult to achieve due to changing temperature and pressure during the prove sequence. Calculating repeatability based upon the calculated meter factor takes into account variations in temperature and pressure, and may be easier to achieve.

{L2} Run Repeatability Maximum Deviation % _____

Enter the maximum allowable percentage deviation between run counts or run meter factors (depending on selection of previous entry). The deviation is calculated by comparing the high/low meter counts or meter factors based on their low point, as follows:

$$\text{Deviation} = 100 (\text{High} - \text{Low}) / \text{Low Point}$$

This deviation is always calculated using the meter factor when the Master Meter Method of proving is selected.

INFO - Characters in '{ }' refer to password levels.

TIP - Use the blank lines provided next to each configuration option to write down the corresponding settings you entered in the flow computer.

{L2} Meter Factor Deviation % from Meter Factor Curve _____

The maximum % deviation allowed between the new calculated meter factor and the interpolated meter factor obtained from the 'meter factor curve' for the current product (see '**Product Setup**' this chapter).

{L2} Number of Meter Factors in Historical Average _____

A maximum of 10 previous meter factors (normalized to base prove flow rate) can be stored and averaged for comparison with the new (normalized) meter factor just calculated.

{L2} Meter Factor Deviation % from Historical Average _____

The maximum % deviation allowed between the average of all stored historical meter factors for the current product and the new calculated meter factor (normalized to the base prove flow rate).

{L2} Automatic Meter Factor Implementation? _____

Enter **[Y]** to automatically implement the new meter factor and store in the appropriate product file. Enter **[N]** to select not to automatically implement the meter factor determined from the prove.

{L2} Apply Meter Factor Retroactively? _____

If you selected to auto-implement the meter factor for the previous entry, enter **[Y]** to retroactively apply the Meter Factor from the beginning of the batch. The old meter factor will be back calculated out of the current batch and daily totals. The batch and daily totals will be recalculated using the new meter factor. Enter **[N]** to have the Meter Factor applied from this point on.

{L2} Manual Implementation Time Limit _____

In cases where 'Automatic Meter Factor Implementation' is not selected, the meter factor just calculated can be implemented manually by activating Modbus point **1787** within this number of minutes after the prove is completed. Activating point **1787** after the time limit will have no effect.

{L2} Tag Number _____

{L2} Manufacturer _____

{L2} Material _____

{L2} Serial Number _____

{L2} Arc All Reports (Y/N) _____

{L2} Uni-direction Reports (Y/N) _____

2.14. Configuring Products

INFO - The first menu, 'Misc Configuration', should always be completed first as these entries specify the number and type of input and output devices connected to the flow computer; i.e., the menus following the 'Misc Configuration' menu do not ask for configuration data unless a transducer has been defined.

Flow Computer Configuration via the Menu Selection Method - It is best to use this method when programming an application for the first time as every possible option and variable will be prompted. Once a computer is in operation and you become familiar with the application you can decide to use the faster Random Access Method described below. Once you have finished entering data in a setup submenu, press the **[Prog]** key to return to the 'Select Group Entry' screen. Proceed as described in this manual for each setup option.

Product Setup via the Random Access Method - Setup entries require that you be in the Program Mode. In the Display Mode press the **[Prog]** key. The Program LED will glow green and the 'Select Group Entry' screen will appear. Then press **[Product] [Enter]** or **[Product] [n] [Enter]** (*n = Product # 1 through 8*). Use **[↑] / [↓]** keys to scroll.

2.14.1. Accessing the Product Setup Submenu

Applying the Menu Selection Method (see sidebar), in the 'Select Group Entry' screen (Program Mode) press **[Setup] [Enter]** and a menu similar to the following will be displayed:

```

***  SETUP MENU  ***
PID Control Setup
Prover Setup
Product Setup  _
    
```

Use the **[↑]/[↓]** (up/down arrow) keys to move the cursor to 'Product Setup' and press **[Enter]** to access the submenu.

2.14.2. Product Settings

Product #1

{L1} Name _____
 Enter the name of the product (up to 8 alphanumeric characters), right justified.

{L1} Table Select _____
 Enter the number that corresponds to the API or GPA table to use for the product:

- 0 = API 2540 Table 24A (US units) / Table 54A (metric units).
- 1 = API 2540 Table 24B (US units) / Table 54B (metric units).
- 2 = Table 24C (US units) / Table 54C (metric units).
- 3 = GPA TP16 (US units) / TP16M (metric units).
- 4 = Table 24 - 1952 Edition (US units) / Table 54 - 1952 Edition (metric units)
- 5 = E/P Mixture
- 15 = GPA TP27 23E/24E
- 28 = API 11.1 2004 Crude Oil
- 29 = API 11.1 2004 Refined Products
- 30 = API 11.1 2004 Lubricating Oil
- 31 = API 11.1 2004 Special Applications

{L2} API Relative Density (Gravity) Override _____

This entry applies only to US units (Revision 22). It will appear depending on which table is selected above. Enter the API Gravity at reference conditions. It is used to calculate the Volume Correction Factor (VCF) and the Pressure Correction Factor (CPL). The flow computer will accept any positive override value and use it as the API in calculations. The override gravity can also be entered as specific gravity (see next entry).

To use the live measured density or gravity value (obtained from a densitometer/gravitometer) in the equations, enter any minus number. The flow computer will then correct the signal from the densitometer or gravitometer to 60°F, if required (this may be flowing at flowing or reference conditions - see Meter Run I/O Point Configuration).

Should the gravitometer fail, the flow computer can be made to use the absolute value of the API Gravity Override. If the override code in 'Grav/Density Setup' is set to '5 = On transmitter failure', use absolute value of override SG/API for this product.

INFO - Characters in '{ }' refer to password levels.

TIP - Use the blank lines provided next to each configuration option to write down the corresponding settings you entered in the flow computer.

INFO - The following data, rounded to 4 digits, is from GPA 2145-92 and TP16:

Product	S.G.	kg/m ³
Ethane	.3562	355.85
Propane	.5070	506.90
HD5	.5010	500.50
	.5050	504.50
	.5100	509.50
Propylene	.5228*	522.28*
Iso Butane	.5629	562.34
	.5650	564.44
n-Butane	.5840	583.42
	.5850	584.42
Iso Pentane	.6247	624.08
n-Pentane	.6311	630.48
n-Hexane	.6638	663.14
Natural Gasolines		
	.6650	664.34
n-Heptane	.6882	687.52
n-Octane	.7070	706.30
n-Nonane	.7219	721.19
n-Decane	.7342	733.48

* Propylene figures are derived from API 11.3.3.2.

INFO - API 2540; Tables 23A or 23B (US), or 53A or 53B (metric); are also automatically used when applicable.

Tables 24A and 53A apply to Generalized Crude Oils (SG range: 1.076-.6110; Dens range: 1075-610.4).

Tables 24B and 53B apply to Generalized Products (SG range: 1.076-.6535; Dens range: 1075-652.8).

GPA TP16 and TP16M apply to LPG/NGL Products (SG range: .637-.495 on Version 20, and 636.4-494.5 on Version 24 of the OMNI).

These calculation methods use API Chapter 11.2.1 or 11.2.2, and 11.2.1M or 11.2.2M to calculate the pressure correction factor 'CPL'.

{L2} Relative Density (SG) Override

This entry applies only to US units (Revision 22). It will appear depending on which table is selected above. You may enter an override gravity as either API or SG units when measuring crude oil or generalized refined products. The Computer will accept any positive override value and use it in the calculations.

To use the live measured density or gravity value (obtained from a densitometer/gravitometer) in the equations, enter any minus number. The flow computer will then correct the signal from the densitometer or gravitometer to 60°F, if required (this may be flowing at flowing or reference conditions - see Meter Run I/O Point Configuration).

Should the gravitometer fail, the flow computer can be made to use the absolute value of the API Gravity Override. If the override code in Grav/Density Setup is set to '5=On transmitter failure', use absolute value of override SG/API for this product.

{L2} Reference Density Override

This entry applies only to metric units (Revision 26) depending on which table is selected above. This is the density at reference conditions (kg/m³ at reference temperature). It is used to calculate the volume correction factor 'VCF' and the pressure correction factor 'CPL'.

Using a Live Densitometer Signal - Entering a value with a minus sign ahead of it causes the flow computer to use the live density signal to calculate the density at reference temperature.

Using the Product Override if the Densitometer Fails - Selecting 'fail code 5' at the densitometer setup menu will cause the flow computer to stop using the live density signal should it fail, and substitute the absolute value of the density override entry as the reference density. E.g.: Entering -750 causes the computer to ignore the override and use the live densitometer signal as long as the transducer is OK. A reference density of 750 kg/m³ will be used if the densitometer should fail.

{L2} Reference Temperature

This entry applies only to metric units (Revision 26). Enter the base or reference temperature in °C at which net corrected volumes represent equivalent volumes of liquid.

{L2} Alpha Coefficient

This entry applies depending on which table is selected above. API 2540, Tables 24C/54C equations require you to enter a value for 'alpha'. This alpha value is used to calculate the volume correction factor 'VCF'. Enter the thermal expansion coefficient at reference temperature as 0.000xxxx.

{L2} F Factor Override

This entry applies depending on which table is selected above. Enter 0.0 if you wish the flow computer to use API 11.2.1 or 11.2.2 to calculate the compressibility factor 'F' used in the Cpl equation. Enter the compressibility factor 'F' if you wish to override the API calculated value.

{L2} Vapor Pressure at 100°F (37.8°C)

This entry applies only when GPA TP16 (or TP16M) is entered for table select. The GPA TP16 standard specifies that the equilibrium pressure of the flowing fluid be calculated according to GPA TP15. Two equations are specified. The first designed for mainly pure products such as propanes, butanes and natural gasolines requires no input data other than the temperature at flowing conditions and the specific gravity at reference conditions. The second improved correlation is suitable for use with more varied NGL mixes where different product mixes could have the same specific gravity but different equilibrium pressures. If you wish to use the improved second method enter the vapor pressure at 100°F or 37.8°C. Enter a minus number to use the normal TP15 method for propanes, butanes and natural gasolines.

{L1A} Density Factor A/B

Density correction factor. Enter [0] to select Density Factor A to correct the densitometer. Enter [1] to select Density Factor B to correct the densitometer.

Meter #1 Meter #2 Meter #3 Meter #4

INFO - Characters in '{ }' refer to password levels.

TIP - Use the blank lines provided next to each configuration option to write down the corresponding settings you entered in the flow computer.

Product Setup via the Random Access Method - Setup entries require that you be in the Program Mode. In the Display Mode press the [Prog] key. The Program LED will glow green and the 'Select Group Entry' screen will appear. Then press [Product] [Enter] or [Product] [n] [Enter] (n = Product # 1 through 8). Use [↑] / [↓] keys to scroll.

{L1A} Date of Meter Factor Curve _____

Use this entry to record the date which helps identify when the meter factor curve was determined.

{L1A} Meter Factor #1 _____

Up to twelve meter factors per product / per meter can be entered. The flow computer dynamically interpolates the curve to determine the correct factor to apply at any flow rate.

{L1A} Flow Rate #1 _____

Enter the flow rate that existed when the meter factor was determined. Up to twelve meter factor/flow rates can be entered per meter per product. Data sets must be entered lowest flow rate first working up to maximum flow rate last.

{L1A} Meter Factor #2 _____

{L1A} Flow Rate #2 _____

{L1A} Meter Factor #3 _____

{L1A} Flow Rate #3 _____

{L1A} Meter Factor #4 _____

{L1A} Flow Rate #4 _____

{L1A} Meter Factor #5 _____

{L1A} Flow Rate #5 _____

{L1A} Meter Factor #6 _____

{L1A} Flow Rate #6 _____

{L1A} Meter Factor #7 _____

{L1A} Flow Rate #7 _____

{L1A} Meter Factor #8 _____

{L1A} Flow Rate #8 _____

{L1A} Meter Factor #9 _____

{L1A} Flow Rate #9 _____

{L1A} Meter Factor #10 _____

{L1A} Flow Rate #10 _____

{L1A} Meter Factor #11 _____

{L1A} Flow Rate #11 _____

{L1A} Meter Factor #12 _____

{L1A} Flow Rate #12 _____

INFO - The following data, rounded to 4 digits, is from GPA 2145-92 and TP16:

Product	S.G.	kg/m ³
Ethane	.3562	355.85
Propane	.5070	506.90
HD5	.5010	500.50
	.5050	504.50
	.5100	509.50
Propylene	.5228*	522.28*
Iso Butane	.5629	562.34
	.5650	564.44
n-Butane	.5840	583.42
	.5850	584.42
Iso Pentane	.6247	624.08
n-Pentane	.6311	630.48
n-Hexane	.6638	663.14
Natural Gasolines		
	.6650	664.34
n-Heptane	.6882	687.52
n-Octane	.7070	706.30
n-Nonane	.7219	721.19
n-Decane	.7342	733.48

* Propylene figures are derived from API 11.3.3.2.

INFO - API 2540; Tables 23A or 23B (US), or 53A or 53B (metric); are also automatically used when applicable.

Tables 24A and 53A apply to Generalized Crude Oils (SG range: 1.076-.6110; Dens range: 1075-610.4).

Tables 24B and 53B apply to Generalized Products (SG range: 1.076-.6535; Dens range: 1075-652.8).

GPA TP16 and TP16M apply to LPG/NGL Products (SG range: .637-.495 on Version 20, and 636.4-494.5 on Version 24 of the OMNI).

These calculation methods use API Chapter 11.2.1 or 11.2.2, and 11.2.1M or 11.2.2M to calculate the pressure correction factor 'CPL'.

Product #2

{L1} Name	_____
{L1} Table Select	_____
{L2} API Relative Density (Gravity) Override	_____
{L2} Relative Density (SG) Override	_____
{L2} Reference Density Override	_____
{L2} Reference Temperature	_____
{L2} Alpha Coefficient	_____
{L2} F Factor Override	_____
{L2} Vapor Pressure at 100°F (37.8°C)	_____
{L1A} Density Factor A/B	_____
	<u>Meter #1</u> <u>Meter #2</u> <u>Meter #3</u> <u>Meter #4</u>
{L1A} Date of Meter Factor Curve	_____
{L1A} Meter Factor #1	_____
{L1A} Flow Rate #1	_____
{L1A} Meter Factor #2	_____
{L1A} Flow Rate #2	_____
{L1A} Meter Factor #3	_____
{L1A} Flow Rate #3	_____
{L1A} Meter Factor #4	_____
{L1A} Flow Rate #4	_____
{L1A} Meter Factor #5	_____
{L1A} Flow Rate #5	_____
{L1A} Meter Factor #6	_____
{L1A} Flow Rate #6	_____
{L1A} Meter Factor #7	_____
{L1A} Flow Rate #7	_____
{L1A} Meter Factor #8	_____
{L1A} Flow Rate #8	_____
{L1A} Meter Factor #9	_____
{L1A} Flow Rate #9	_____
{L1A} Meter Factor #10	_____
{L1A} Flow Rate #10	_____
{L1A} Meter Factor #11	_____
{L1A} Flow Rate #11	_____
{L1A} Meter Factor #12	_____
{L1A} Flow Rate #12	_____

INFO - Characters in '{ }' refer to password levels.

TIP - Use the blank lines provided next to each configuration option to write down the corresponding settings you entered in the flow computer.

Product Setup via the Random Access Method - Setup entries require that you be in the Program Mode. In the Display Mode press the **[Prog]** key. The Program LED will glow *green* and the **'Select Group Entry'** screen will appear. Then press **[Product] [Enter]** or **[Product] [n] [Enter]** (*n = Product # 1 through 8*). Use **[↑] / [↓]** keys to scroll.

Product #3

{L1} Name	_____			
{L1} Table Select	_____			
{L2} API Relative Density (Gravity) Override	_____			
{L2} Relative Density (SG) Override	_____			
{L2} Reference Density Override	_____			
{L2} Reference Temperature	_____			
{L2} Alpha Coefficient	_____			
{L2} F Factor Override	_____			
{L2} Vapor Pressure at 100°F (37.8°C)	_____			
{L1A} Density Factor A/B	_____			
	<u>Meter #1</u>	<u>Meter #2</u>	<u>Meter #3</u>	<u>Meter #4</u>
{L1A} Date of Meter Factor Curve	_____	_____	_____	_____
{L1A} Meter Factor #1	_____	_____	_____	_____
{L1A} Flow Rate #1	_____	_____	_____	_____
{L1A} Meter Factor #2	_____	_____	_____	_____
{L1A} Flow Rate #2	_____	_____	_____	_____
{L1A} Meter Factor #3	_____	_____	_____	_____
{L1A} Flow Rate #3	_____	_____	_____	_____
{L1A} Meter Factor #4	_____	_____	_____	_____
{L1A} Flow Rate #4	_____	_____	_____	_____
{L1A} Meter Factor #5	_____	_____	_____	_____
{L1A} Flow Rate #5	_____	_____	_____	_____
{L1A} Meter Factor #6	_____	_____	_____	_____
{L1A} Flow Rate #6	_____	_____	_____	_____
{L1A} Meter Factor #7	_____	_____	_____	_____
{L1A} Flow Rate #7	_____	_____	_____	_____
{L1A} Meter Factor #8	_____	_____	_____	_____
{L1A} Flow Rate #8	_____	_____	_____	_____
{L1A} Meter Factor #9	_____	_____	_____	_____
{L1A} Flow Rate #9	_____	_____	_____	_____
{L1A} Meter Factor #10	_____	_____	_____	_____
{L1A} Flow Rate #10	_____	_____	_____	_____
{L1A} Meter Factor #11	_____	_____	_____	_____
{L1A} Flow Rate #11	_____	_____	_____	_____
{L1A} Meter Factor #12	_____	_____	_____	_____
{L1A} Flow Rate #12	_____	_____	_____	_____

INFO - The following data, rounded to 4 digits, is from GPA 2145-92 and TP16:

Product	S.G.	kg/m ³
Ethane	.3562	355.85
Propane	.5070	506.90
HD5	.5010	500.50
	.5050	504.50
	.5100	509.50
Propylene	.5228*	522.28*
Iso Butane	.5629	562.34
	.5650	564.44
n-Butane	.5840	583.42
	.5850	584.42
Iso Pentane	.6247	624.08
n-Pentane	.6311	630.48
n-Hexane	.6638	663.14
Natural Gasolines		
	.6650	664.34
n-Heptane	.6882	687.52
n-Octane	.7070	706.30
n-Nonane	.7219	721.19
n-Decane	.7342	733.48

* Propylene figures are derived from API 11.3.3.2.

INFO - API 2540; Tables 23A or 23B (US), or 53A or 53B (metric); are also automatically used when applicable.

Tables 24A and 53A apply to Generalized Crude Oils (SG range: 1.076-.6110; Dens range: 1075-610.4).

Tables 24B and 53B apply to Generalized Products (SG range: 1.076-.6535; Dens range: 1075-652.8).

GPA TP16 and TP16M apply to LPG/NGL Products (SG range: .637-.495 on Version 20, and 636.4-494.5 on Version 24 of the OMNI).

These calculation methods use API Chapter 11.2.1 or 11.2.2, and 11.2.1M or 11.2.2M to calculate the pressure correction factor 'CPL'.

Product #4

{L1} Name	_____	_____	_____	_____
{L1} Table Select	_____	_____	_____	_____
{L2} API Relative Density (Gravity) Override	_____	_____	_____	_____
{L2} Relative Density (SG) Override	_____	_____	_____	_____
{L2} Reference Density Override	_____	_____	_____	_____
{L2} Reference Temperature	_____	_____	_____	_____
{L2} Alpha Coefficient	_____	_____	_____	_____
{L2} F Factor Override	_____	_____	_____	_____
{L2} Vapor Pressure at 100°F (37.8°C)	_____	_____	_____	_____
{L1A} Density Factor A/B	_____	_____	_____	_____
		<u>Meter #1</u>	<u>Meter #2</u>	<u>Meter #3</u> <u>Meter #4</u>
{L1A} Date of Meter Factor Curve	_____	_____	_____	_____
{L1A} Meter Factor #1	_____	_____	_____	_____
{L1A} Flow Rate #1	_____	_____	_____	_____
{L1A} Meter Factor #2	_____	_____	_____	_____
{L1A} Flow Rate #2	_____	_____	_____	_____
{L1A} Meter Factor #3	_____	_____	_____	_____
{L1A} Flow Rate #3	_____	_____	_____	_____
{L1A} Meter Factor #4	_____	_____	_____	_____
{L1A} Flow Rate #4	_____	_____	_____	_____
{L1A} Meter Factor #5	_____	_____	_____	_____
{L1A} Flow Rate #5	_____	_____	_____	_____
{L1A} Meter Factor #6	_____	_____	_____	_____
{L1A} Flow Rate #6	_____	_____	_____	_____
{L1A} Meter Factor #7	_____	_____	_____	_____
{L1A} Flow Rate #7	_____	_____	_____	_____
{L1A} Meter Factor #8	_____	_____	_____	_____
{L1A} Flow Rate #8	_____	_____	_____	_____
{L1A} Meter Factor #9	_____	_____	_____	_____
{L1A} Flow Rate #9	_____	_____	_____	_____
{L1A} Meter Factor #10	_____	_____	_____	_____
{L1A} Flow Rate #10	_____	_____	_____	_____
{L1A} Meter Factor #11	_____	_____	_____	_____
{L1A} Flow Rate #11	_____	_____	_____	_____
{L1A} Meter Factor #12	_____	_____	_____	_____
{L1A} Flow Rate #12	_____	_____	_____	_____

INFO - Characters in '{ }' refer to password levels.

TIP - Use the blank lines provided next to each configuration option to write down the corresponding settings you entered in the flow computer.

Product Setup via the Random Access Method - Setup entries require that you be in the Program Mode. In the Display Mode press the **[Prog]** key. The Program LED will glow *green* and the **'Select Group Entry'** screen will appear. Then press **[Product] [Enter]** or **[Product] [n] [Enter]** (*n = Product # 1 through 8*). Use **[↑] / [↓]** keys to scroll.

Product #5

{L1} Name	_____			
{L1} Table Select	_____			
{L2} API Relative Density (Gravity) Override	_____			
{L2} Relative Density (SG) Override	_____			
{L2} Reference Density Override	_____			
{L2} Reference Temperature	_____			
{L2} Alpha Coefficient	_____			
{L2} F Factor Override	_____			
{L2} Vapor Pressure at 100°F (37.8°C)	_____			
{L1A} Density Factor A/B	_____			
		<u>Meter #1</u>	<u>Meter #2</u>	<u>Meter #3</u> <u>Meter #4</u>
{L1A} Date of Meter Factor Curve	_____	_____	_____	_____
{L1A} Meter Factor #1	_____	_____	_____	_____
{L1A} Flow Rate #1	_____	_____	_____	_____
{L1A} Meter Factor #2	_____	_____	_____	_____
{L1A} Flow Rate #2	_____	_____	_____	_____
{L1A} Meter Factor #3	_____	_____	_____	_____
{L1A} Flow Rate #3	_____	_____	_____	_____
{L1A} Meter Factor #4	_____	_____	_____	_____
{L1A} Flow Rate #4	_____	_____	_____	_____
{L1A} Meter Factor #5	_____	_____	_____	_____
{L1A} Flow Rate #5	_____	_____	_____	_____
{L1A} Meter Factor #6	_____	_____	_____	_____
{L1A} Flow Rate #6	_____	_____	_____	_____
{L1A} Meter Factor #7	_____	_____	_____	_____
{L1A} Flow Rate #7	_____	_____	_____	_____
{L1A} Meter Factor #8	_____	_____	_____	_____
{L1A} Flow Rate #8	_____	_____	_____	_____
{L1A} Meter Factor #9	_____	_____	_____	_____
{L1A} Flow Rate #9	_____	_____	_____	_____
{L1A} Meter Factor #10	_____	_____	_____	_____
{L1A} Flow Rate #10	_____	_____	_____	_____
{L1A} Meter Factor #11	_____	_____	_____	_____
{L1A} Flow Rate #11	_____	_____	_____	_____
{L1A} Meter Factor #12	_____	_____	_____	_____
{L1A} Flow Rate #12	_____	_____	_____	_____

INFO - The following data, rounded to 4 digits, is from GPA 2145-92 and TP16:

Product	S.G.	kg/m ³
Ethane	.3562	355.85
Propane	.5070	506.90
HD5	.5010	500.50
	.5050	504.50
	.5100	509.50
Propylene	.5228*	522.28*
Iso Butane	.5629	562.34
	.5650	564.44
n-Butane	.5840	583.42
	.5850	584.42
Iso Pentane	.6247	624.08
n-Pentane	.6311	630.48
n-Hexane	.6638	663.14
Natural Gasolines		
	.6650	664.34
n-Heptane	.6882	687.52
n-Octane	.7070	706.30
n-Nonane	.7219	721.19
n-Decane	.7342	733.48

* Propylene figures are derived from API 11.3.3.2.

INFO - API 2540; Tables 23A or 23B (US), or 53A or 53B (metric); are also automatically used when applicable.

Tables 24A and 53A apply to Generalized Crude Oils (SG range: 1.076-.6110; Dens range: 1075-610.4).

Tables 24B and 53B apply to Generalized Products (SG range: 1.076-.6535; Dens range: 1075-652.8).

GPA TP16 and TP16M apply to LPG/NGL Products (SG range: .637-.495 on Version 20, and 636.4-494.5 on Version 24 of the OMNI).

These calculation methods use API Chapter 11.2.1 or 11.2.2, and 11.2.1M or 11.2.2M to calculate the pressure correction factor 'CPL'.

Product #6

{L1} Name	_____
{L1} Table Select	_____
{L2} API Relative Density (Gravity) Override	_____
{L2} Relative Density (SG) Override	_____
{L2} Reference Density Override	_____
{L2} Reference Temperature	_____
{L2} Alpha Coefficient	_____
{L2} F Factor Override	_____
{L2} Vapor Pressure at 100°F (37.8°C)	_____
{L1A} Density Factor A/B	_____
	<u>Meter #1</u> <u>Meter #2</u> <u>Meter #3</u> <u>Meter #4</u>
{L1A} Date of Meter Factor Curve	_____
{L1A} Meter Factor #1	_____
{L1A} Flow Rate #1	_____
{L1A} Meter Factor #2	_____
{L1A} Flow Rate #2	_____
{L1A} Meter Factor #3	_____
{L1A} Flow Rate #3	_____
{L1A} Meter Factor #4	_____
{L1A} Flow Rate #4	_____
{L1A} Meter Factor #5	_____
{L1A} Flow Rate #5	_____
{L1A} Meter Factor #6	_____
{L1A} Flow Rate #6	_____
{L1A} Meter Factor #7	_____
{L1A} Flow Rate #7	_____
{L1A} Meter Factor #8	_____
{L1A} Flow Rate #8	_____
{L1A} Meter Factor #9	_____
{L1A} Flow Rate #9	_____
{L1A} Meter Factor #10	_____
{L1A} Flow Rate #10	_____
{L1A} Meter Factor #11	_____
{L1A} Flow Rate #11	_____
{L1A} Meter Factor #12	_____
{L1A} Flow Rate #12	_____

INFO - Characters in '{ }' refer to password levels.

TIP - Use the blank lines provided next to each configuration option to write down the corresponding settings you entered in the flow computer.

Product Setup via the Random Access Method - Setup entries require that you be in the Program Mode. In the Display Mode press the **[Prog]** key. The Program LED will glow *green* and the **'Select Group Entry'** screen will appear. Then press **[Product] [Enter]** or **[Product] [n] [Enter]** (*n = Product # 1 through 8*). Use **[↑] / [↓]** keys to scroll.

Product #7

{L1} Name	_____			
{L1} Table Select	_____			
{L2} API Relative Density (Gravity) Override	_____			
{L2} Relative Density (SG) Override	_____			
{L2} Reference Density Override	_____			
{L2} Reference Temperature	_____			
{L2} Alpha Coefficient	_____			
{L2} F Factor Override	_____			
{L2} Vapor Pressure at 100°F (37.8°C)	_____			
{L1A} Density Factor A/B	_____			
		<u>Meter #1</u>	<u>Meter #2</u>	<u>Meter #3</u> <u>Meter #4</u>
{L1A} Date of Meter Factor Curve	_____	_____	_____	_____
{L1A} Meter Factor #1	_____	_____	_____	_____
{L1A} Flow Rate #1	_____	_____	_____	_____
{L1A} Meter Factor #2	_____	_____	_____	_____
{L1A} Flow Rate #2	_____	_____	_____	_____
{L1A} Meter Factor #3	_____	_____	_____	_____
{L1A} Flow Rate #3	_____	_____	_____	_____
{L1A} Meter Factor #4	_____	_____	_____	_____
{L1A} Flow Rate #4	_____	_____	_____	_____
{L1A} Meter Factor #5	_____	_____	_____	_____
{L1A} Flow Rate #5	_____	_____	_____	_____
{L1A} Meter Factor #6	_____	_____	_____	_____
{L1A} Flow Rate #6	_____	_____	_____	_____
{L1A} Meter Factor #7	_____	_____	_____	_____
{L1A} Flow Rate #7	_____	_____	_____	_____
{L1A} Meter Factor #8	_____	_____	_____	_____
{L1A} Flow Rate #8	_____	_____	_____	_____
{L1A} Meter Factor #9	_____	_____	_____	_____
{L1A} Flow Rate #9	_____	_____	_____	_____
{L1A} Meter Factor #10	_____	_____	_____	_____
{L1A} Flow Rate #10	_____	_____	_____	_____
{L1A} Meter Factor #11	_____	_____	_____	_____
{L1A} Flow Rate #11	_____	_____	_____	_____
{L1A} Meter Factor #12	_____	_____	_____	_____
{L1A} Flow Rate #12	_____	_____	_____	_____

INFO - The following data, rounded to 4 digits, is from GPA 2145-92 and TP16:

Product	S.G.	kg/m ³
Ethane	.3562	355.85
Propane	.5070	506.90
HD5	.5010	500.50
	.5050	504.50
	.5100	509.50
Propylene	.5228*	522.28*
Iso Butane	.5629	562.34
	.5650	564.44
n-Butane	.5840	583.42
	.5850	584.42
Iso Pentane	.6247	624.08
n-Pentane	.6311	630.48
n-Hexane	.6638	663.14
Natural Gasolines		
	.6650	664.34
n-Heptane	.6882	687.52
n-Octane	.7070	706.30
n-Nonane	.7219	721.19
n-Decane	.7342	733.48

* Propylene figures are derived from API 11.3.3.2.

INFO - API 2540; Tables 23A or 23B (US), or 53A or 53B (metric); are also automatically used when applicable.

Tables 24A and 53A apply to Generalized Crude Oils (SG range: 1.076-.6110; Dens range: 1075-610.4).

Tables 24B and 53B apply to Generalized Products (SG range: 1.076-.6535; Dens range: 1075-652.8).

GPA TP16 and TP16M apply to LPG/NGL Products (SG range: .637-.495 on Version 20, and 636.4-494.5 on Version 24 of the OMNI).

These calculation methods use API Chapter 11.2.1 or 11.2.2, and 11.2.1M or 11.2.2M to calculate the pressure correction factor 'CPL'.

Product #8

{L1} Name	_____
{L1} Table Select	_____
{L2} API Relative Density (Gravity) Override	_____
{L2} Relative Density (SG) Override	_____
{L2} Reference Density Override	_____
{L2} Reference Temperature	_____
{L2} Alpha Coefficient	_____
{L2} F Factor Override	_____
{L2} Vapor Pressure at 100°F (37.8°C)	_____
{L1A} Density Factor A/B	_____
	<u>Meter #1</u> <u>Meter #2</u> <u>Meter #3</u> <u>Meter #4</u>
{L1A} Date of Meter Factor Curve	_____
{L1A} Meter Factor #1	_____
{L1A} Flow Rate #1	_____
{L1A} Meter Factor #2	_____
{L1A} Flow Rate #2	_____
{L1A} Meter Factor #3	_____
{L1A} Flow Rate #3	_____
{L1A} Meter Factor #4	_____
{L1A} Flow Rate #4	_____
{L1A} Meter Factor #5	_____
{L1A} Flow Rate #5	_____
{L1A} Meter Factor #6	_____
{L1A} Flow Rate #6	_____
{L1A} Meter Factor #7	_____
{L1A} Flow Rate #7	_____
{L1A} Meter Factor #8	_____
{L1A} Flow Rate #8	_____
{L1A} Meter Factor #9	_____
{L1A} Flow Rate #9	_____
{L1A} Meter Factor #10	_____
{L1A} Flow Rate #10	_____
{L1A} Meter Factor #11	_____
{L1A} Flow Rate #11	_____
{L1A} Meter Factor #12	_____
{L1A} Flow Rate #12	_____

2.15. Configuring Batches

INFO - Characters in '{ }' refer to password levels.

TIP - Use the blank lines provided next to each configuration option to write down the corresponding settings you entered in the flow computer.

Note: See *Chapter 3 “Computer Batching Operations” in Volume 2* for information on configuring your flow computer for batches.

2.15.1. Batch Preset Setup

```

*** SETUP MENU ***
Batch Preset Setup
Batch Sequence
Factor Setup      _
    
```

{L1} Adjust #1 Batch Size

Enter Amount to Adjust _____

Enter a positive or a negative number to adjust the size of the current running batch.

Size Now _____

Displays the current batch size.

{L1} Batch Sequence

Meter #1 Current Batch: _____

Each Meter in the Common Batch Stack N entry can be setup with a batch sequence of up to 6 different batches. If the Batch Stack is Y (Common on all meters) then 16 batch sequences can be entered.

ID: _____

Customer Batch ID number

Running Product _____

Current running product #.

Size BBL/M3 _____

Current Batch size

M1: 1 I=Ins D=Del ?

Batch Meter #1 I= Insert a new batch into the batch sequence or D= delete a batch sequence.

ID:

Installing or Deleting Batch ID number

Product to Run?

Select the product # to be setup in the new batch sequence.

Size BBL/M3

Enter the new Batch size.

2.16. Configuring Miscellaneous Factors

INFO - The first menu, 'Misc Configuration', should always be completed first as these entries specify the number and type of input and output devices connected to the flow computer; i.e., the menus following the 'Misc Configuration' menu do not ask for configuration data unless a transducer has been defined.

Flow Computer Configuration via the Menu Selection Method - It is best to use this method when programming an application for the first time as every possible option and variable will be prompted. Once a computer is in operation and you become familiar with the application you can decide to use the faster Random Access Method described below. Once you have finished entering data in a setup submenu, press the [Prog] key to return to the 'Select Group Entry' screen. Proceed as described in this manual for each setup option.

Factor Setup via the Random Access Method - Setup entries require that you be in the Program Mode. In the Display Mode press the [Prog] key. The Program LED will glow green and the 'Select Group Entry' screen will appear. Then press [[Factor] [Enter], or [Factor] [Meter] [n] [Enter], or [Meter] [n] [Factor]](n = Meter Run # 1, 2, 3, or 4). Use [↑] / [↓] keys to scroll.

2.16.1. Accessing the Factor Setup Submenu

Applying the Menu Selection Method (see sidebar), in the 'Select Group Entry' screen (Program Mode) press [Setup] [Enter] and a menu similar to the following will be displayed:

```

***  SETUP MENU  ***
Batch Preset Setup
Batch Sequence
Factor Setup      _
    
```

Use the [↑]/[↓] (up/down arrow) keys to move the cursor to 'Factor Setup' and press [Enter] to access the submenu.

2.16.2. Factor Settings

{L1} Weight of Water

Also known as absolute density of water. Weight of a barrel of water at 60°F or 15°C, and 14.696 PSia or 101.325 kPa(a). Used to convert from specific gravity units to mass. (From GPA 2145-92 = 8.3372 Lbm/Gal = 350.161 Lbs/Bbl).

Note: This is the true weight of water, NOT the conversion factor used to convert grs/cc to Lbs/Bbl sometimes given as 350.507. For metric versions (Revision 26), the default value is 999.012 kg/m³.

{L1} Flow Average Factor

The flow averaging factor is the number of calculation cycles used to smooth the displayed flow rate. A number 1-99 will be accepted. (A calculation cycle is 500msec).

{L1} Atmospheric Pressure (ABS)

This setting is used to convert flowing pressure readings in Psig to absolute pressure units PSia for US Units, and for the metric version in absolute units in conformance to pressure (metric) units selected.

Number of Digits, 0=9, 1=8

Number of digits for the totalizer displayed

Decimal Places Gross

Decimal Places Net

Decimal Places Mass

The above four entries are **Read Only**. To change these values, the user must go thru the Password Maintenance mode and reset totalizer which will allow the user to change the decimal place resolution for these entries.

2.17. Configuring Printers

INFO - Characters in '{ }' refer to password levels.

TIP - Use the blank lines provided next to each configuration option to write down the corresponding settings you entered in the flow computer.

Printer Setup via the Random Access Method - Setup entries require that you be in the Program Mode. In the Display Mode press the [Prog] key. The Program LED will glow green and the 'Select Group Entry' screen will appear. Then press [Print] [Setup] [Enter] and use [↑] / [↓] keys to scroll.

2.17.1. Accessing the Printer Setup Submenu

Applying the Menu Selection Method (see sidebar), in the 'Select Group Entry' screen (Program Mode) press [Setup] [Enter] and a menu similar to the following will be displayed:

```

***  SETUP MENU  ***
Batch Sequence
Factor Setup
Printer Setup  _
    
```

Use the [↑]/[↓] (up/down arrow) keys to move the cursor to 'Printer Setup' and press [Enter] to access the submenu.

2.17.2. Printer Settings

- {L1} Computer ID** _____

Appears on all reports. Enter up to 8 alphanumeric characters to identify the flow computer.
- {L1} Print Interval in Minutes** _____

Enter the number of minutes between each interval report. Entering [0] will disable interval reports. The maximum allowed is 1440 minutes which will provide one interval report per 24-hour period.
- {L1} Print Interval Start Time** _____ : _____

Enter the start time from which the interval report timer is based (e.g.: Entering '01:00' with a Print Interval of 120 minutes will provide an interval report every odd hour only).
- {L1} Daily Report Time** _____ : _____

Enter the hour at which the daily report will print at the beginning of the contract day (e.g.: 07:00).
- {L1} Disable Daily Report?** _____

Enter [Y] to disable the Daily Report (default is 'N'). This simply blocks the report from printing. Data will still be sent to the historical buffers (last 8) and archive if archive is setup.
- {L1} Daylight Savings Time Start** _____ / _____ / _____

Enter the Day/Month/Year that daylight savings time begins.
- {L1} Daylight Savings Time End** _____ / _____ / _____

Enter the Day/Month/Year that daylight savings time ends.
- {L1} Disable Batch Stack Operation ?** _____
- {L1} Clear Daily Totals at Batch End?** _____

Enter [N] to provide 24 hour totals of all flow through the flowmeter regardless of what product is run. Select [Y] to clear the totalizers at the end of each batch. This would mean that the daily totalizers would not necessarily represent 24 hours of flow but the amount of flow since the last batch end or the daily report

TIP - Use the blank lines provided next to each configuration option to write down the corresponding settings you entered in the flow computer.

{L1} Automatic Hourly Batch Select? _____

Enter [Y] to automatically cause a batch end every hour on the hour. If customized reports are selected a batch end report will be printed. If default reports are selected no batch end report will be printed.

{L1} Automatic Weekly Batch Select? _____

Enter a number 1 through 7 to automatically print a batch end report in addition to a daily report on a specific day of the week (0=No batch end, 1=Monday, 2=Tuesday, etc.).

{L1} Automatic Monthly Batch Select? _____

Enter a number 1 through 31 to automatically print a batch end report in place of a daily report on a specific day of the month (0=No batch end).

{L1} Print Priority _____

Enter [0] when the computer is connected to a dedicated printer. If several computers are sharing a common printer, one computer must be designated as the master and must be assigned the number 1. The remaining computers must each be assigned a different Print Priority number between 2 and 12.

{L1} Number of Nulls _____

For slow printers without an input buffer, a number of null characters can be sent after each carriage return or line feed. A number between 0-255 will be accepted. Set this to '0' if your printer supports hardware handshaking and you have connected pin 20 of the printer connector to terminal 6 of the flow computer (see **Chapter 3**).

{L1} Use Default Snapshot Report? Y _____

Entering [Y] instructs the flow computer to use the default report. Enter [N] if you have downloaded your own custom report t format.

{L1} Use Default Batch Report? Y _____

{L1} Use Default Daily Report? Y _____

{L1} Use Default Prove Report? Y _____

{L1} Condensed Print Mode Control String _____

Certain default report templates exceed 80 columns when the computer is configured for 4 meter runs and a station. Enter the hexadecimal character string which will put the printer into the condensed print mode. Data must be in sets of 2 characters (i.e., 05 not 5). A maximum of 5 control characters are allowed.

{L1} Cancel Condensed Print Mode Control String _____

Uncondensed Print Mode. Enter the hexadecimal character string which when sent to the printer will cancel the condensed print mode. Data must be in sets of 2 characters (i.e., 05 not 5). A maximum of 5 control characters are allowed.

{L1} Company Name _____

Two lines of the display allow entry of the Company Name. On each line enter a maximum of 19 characters and press [Enter]. Both lines are concatenated and appear on all reports.

{L1} Location _____

Two lines of the display allow entry of the station location Name. On each line enter a maximum of 19 characters and press [Enter]. Both lines are concatenated and appear on all reports.

{L1} Checked/Proved for "FOR"

Enter Check/Proved "FOR" String for the ticket or prove report. 16 characters will be accepted.

Common Printer Control Codes -
Epson, IBM & Compatible:
 Condensed Mode= 0F
 Cancel Condensed= 12
OKI Data Models:
 Condensed Mode= 1D
 Cancel Condensed= 1E
HP Laser Jet II & Compatible:
 Condensed= 1B266B3253
 Cancel Cond= 1B266B3053

Chapter 3

User-Programmable Functions

3.1. Introduction

The computer performs many functions, displays and prints large amounts of data, but there are always some application-specific control functions, calculations or displays that cannot be anticipated.

The OMNI Flow Computer incorporates several programmable features that enable the user to easily customize the computer to fit a specific application.

- o User-programmable Boolean Flags and Statements
- o User-programmable Variables and Statements
- o User-configurable Display Screens
- o User-customized Report Templates

The first three items are explained here. The last item requires the use of the OmniCom PC configuration software that comes with the flow computer.

3.2. User-Programmable Boolean Flags and Statements

3.2.1. What is a Boolean?

A Boolean point is simply a single bit register within the computer (sometimes called a flag) which has only two states, On or Off (True or False, 1 or 0). These Boolean flags or points are controlled and/or monitored by the flow computer and represent alarms, commands and status points. Each Boolean point is given an identifying number within the data base of the computer allowing the state (On or Off) to be monitored or modified by assigning that Boolean point to a physical digital I/O point or accessing it via a communication port. A maximum of 24 physical digital I/O points are available for monitoring limit switches, status signals or controlling relays or lamps.

INFO - The 4-digit 'point' numbers referred to in this chapter are Modbus index numbers used to identify each variable (Boolean or other) within the Modbus database. A complete listing and descriptions of database points is included in **Volume 4**.

Boolean points are numbered as follows:

1001 through 1024	Physical Digital I/O Points 1 through 24
1025 through 1088	Programmable Boolean Points (64 total)
1089 through 1099	Programmable Pulse outputs (11 total)
1100 through 1199	Meter Run #1 Boolean Points (Alarms, Status etc.)
1200 through 1299	Meter Run #2 Boolean Points (Alarms, Status etc.)
1300 through 1399	Meter Run #3 Boolean Points (Alarms, Status etc.)
1400 through 1499	Meter Run #4 Boolean Points (Alarms, Status etc.)
1500 through 1699	Scratchpad Storage for Results of Boolean Statements
1700 through 1799	Command or Status Inputs
1800 through 1899	Station Boolean Flags (Alarms, Status etc.)
2100 through 2199	Meter Run #1 Totalizer Roll-over Flags
2200 through 2299	Meter Run #2 Totalizer Roll-over Flags
2300 through 2399	Meter Run #3 Totalizer Roll-over Flags
2400 through 2499	Meter Run #4 Totalizer Roll-over Flags
2600 through 2623	Miscellaneous Station Boolean Points (Alarms, Status etc.)
2700 through 2759	Miscellaneous Boolean Command and Status Points
2800 through 2876	Station Totalizer Roll-over Flags
2877 through 2899	More Miscellaneous Boolean Command and Status Points

Physical Digital I/O Points (1001 → 1024)

Each of the physical digital I/O points is assigned to a valid Boolean point number as detailed above. Points 1700 through 1799 are command inputs which are described later, all other point assignments indicate that the I/O point is to be set up as an output point. Output points which are dedicated as flow accumulator outputs can be set up for pulse widths ranging from 10 msec to 100 sec in 10 msec increments. All other output point assignments have associated 'time ON delay' and 'time OFF delay' timers which are adjustable from 0.0 to 1000 sec in 100 msec increments.

Programmable Boolean Points (1025 → 1088)

There are 64 user flags or Boolean points available and are controlled by 64 Boolean statements or equations. These are provided to perform sequencing and control functions. Each statement or equation is evaluated every 100 msec. starting at point 1025 and ending at point 1088. The results of these Boolean statements can then assigned to physical digital I/O points. There are no restrictions as to what Boolean points can be used in a Boolean statement including the results of other Boolean statements or the status of physical I/O points.

Programmable Accumulator Points (1089 → 1099)

There are 11 Programmable points that are used with Variable Points 7089 through 7099 for programming pulse outputs for Digital I/O or Front Panel Counters.

One-Shot Boolean Points (1501 → 1649)

The 149 Boolean flags located between 1501 and 1650 are used to store temporary data that has been received via the Modbus link or put there by a Boolean statement. These Boolean variables can be sent to a digital output or used in the Boolean statements described above.

Scratch Pad Boolean Points (1650 → 1699)

The 50 Boolean flags located between 1650 and 1699 can be use as momentary commands. When set true they remain on for two seconds.

3.2.2. Sign (+, -) of Analog or Calculated Variables (5001 → 8999)

The sign of analog or calculated variables can also be used in a Boolean statements by simply specifying the point number. The Boolean value of the variable is 'true ' if it is positive and 'false' if it has a negative value.

3.2.3. Boolean Statements and Functions

Each Boolean statement consists of up to 3 variables optionally preceded by the Boolean '**NOT**' function and separated by one of the Boolean functions '**AND**', '**OR**', '**Exclusive OR**' or '**EQUAL**'. The following symbols are used to represent the functions:

<u>Function</u>	<u>Symbol</u>
NOT	/
AND	&
OR	+
EX OR	*
EQUAL	=
IF)
GOTO	'G'
MOVE RANGE	:
COMPARE	%
RISING EDGE	(
FALLING EDGE	(/
ONE SHOT	@

The '=' function allows a statement to be used to change the state of the Boolean point on the left of the equal sign (usually a command point). Evaluation precedence is left to right.

To program the Boolean points proceed as follows:

From the Display Mode press **[Prog] [Setup] [Enter] [Enter]** and the following menu will be displayed:

```
*** Misc. Setup ***
Password Maint?(Y)
Check Modules ?(Y)
Config Station?(Y)
Config Meter "n"
Config PID ? "n"
Config D/A Out "n"
Front Pnl Counters
Program Booleans ? _
Program Variables ?
User Display ? "n"
```

Scroll down to '**Set Boolean ? (Y)**' and enter **[Y]**. Assuming that no Booleans are as yet programmed, the display shows:

```
Boolean Point #10xx
25: _
Rmk
26:
```

Note that the cursor is on the line labeled 25: At this point enter the Boolean equation that will cause Boolean point 1025 to be ON (True) / OFF (False).

INFO - Points 1005 and 1006 reflect the current status of physical I/O Points 05 and 06 which could be inputs connected to the outside world or outputs controlling relays, etc.

For example, to turn Boolean 1025 ON whenever Boolean 1005 is OFF, **OR** whenever 1006 is ON, enter **[/1005+1006]** (note the use of the '/' to indicate the '**NOT**' function).

```
Boolean Point #10XX
25: /1005+1006
Rmk
26: _
```

Boolean 1025 could then be used in the statement following which defines Boolean 1026. For example, by including Boolean 1205 which indicates that Meter #2 is active and flowing (see following page), Boolean 1026 will be ON whenever 'Meter 2 is active and flowing' **AND** (1005 is **NOT ON OR** 1006 is ON).

TIP - Leave plenty of empty statements between programmed ones. This will allow you to modify the execution order of your program if you need to later.

```
Boolean Point #10xx
25: /1005+1006
Rmk
26: 1205&1025
```

Use the 'Up/Down' arrow keys to scroll through all 64 programmable Boolean points.

Remember that the Boolean statements are evaluated in order starting from 1025 proceeding to 1088 . For maximum speed always ensure that statements used in other statements are evaluated ahead of time by placing them in the correct order.

Example 1: Meter Failure Alarm for Two-Meter Run Application

INFO - Use the Exclusive OR function '*' to compare 2 points. The result of an Exclusive OR of 2 points is true only if both points are different states.

INFO - Booleans 1025, 1026 and 1027 are only used as an example here. Any unused programmable Booleans can be used for this function.

Object: Using signals from 'flow sensing switches' inserted into the pipeline, provide an alarm output which activates whenever the signals from the flow switches and flow meter signals differ, also provide a snapshot report by setting command point 1719.

How the hardware is configured:

Physical I/O points 02 and 03 are setup as inputs by assigning them to 1700 (see the Command and Status Booleans on a later page). They are connected to flow sensing switches on meter runs 1 and 2 respectively. The switches activate with flow.

Physical I/O point 04 is connected to a 'meter fail alarm bell'. The output is assigned to Programmable Boolean 1027. A 'delay ON' of 5 seconds is selected to eliminate spurious alarms which would occur during startup and shutdown. A 'delay OFF' of 5 seconds is selected to ensure that the alarm bell remains on for at least 5 seconds.

The Booleans are programmed as follows:

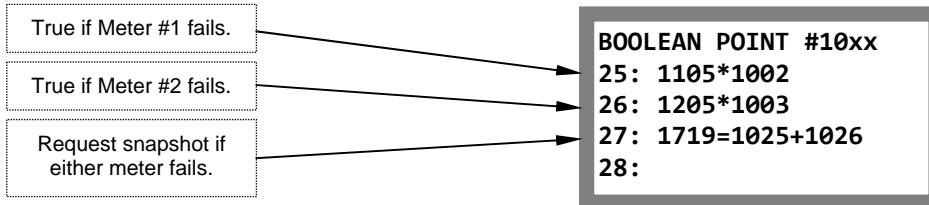

Notes:

- Ø Boolean Point 1025 is true (Meter 1 failed) whenever 'Meter 1 Active' (Point 1105) differs from 'Flow Detected' Flow Switch 1 (Point 02).
- Ø Boolean Point 1026 is true (Meter 2 failed) whenever 'Meter 2 Active' (Point 1205) differs from 'Flow Detected' Flow Switch 2 (Point 03).
- Ø Boolean Point 1027 is true (Meter 1 OR 2 failed) whenever point 1025 OR 0126 are true. The Boolean Command Bit 1719 is set when Boolean Point 1027 is true.

Example 2: Automatic Run Switching for 4-Meter Run Application

Object: To improve metering accuracy by automatically selecting the correct flow meter run to be active in a multi run application. Small turbines need to be protected from over-speeding while for best accuracy larger turbines should be valved off when the flow drops below their minimum rate. In the example shown, except when switching from one flow meter to the other, only one flow meter run is active at one time. This is one example only. The number of runs open for a given application at any flow rate obviously depends on the size of the flow meters used.

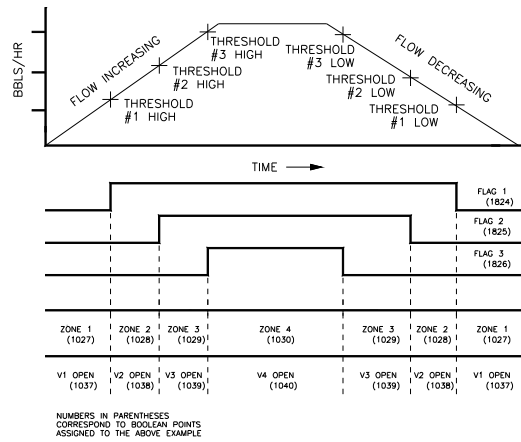

Fig. 3-1. Figure Showing Automatic Four-Meter Flow Zone Thresholds

Switching is based on the station flow gross flow rate which is compared to preset switching thresholds entered by the user (See 'Meter Station Settings' in **Chapter 2**). Threshold Flags 1, 2 and 3 are set and reset according to the actual station flow rate.

The first task is to identify the 4 zones and assign programmable Boolean points to them. This allows us to include them in further Boolean statements.

- Zone 1 = **NOT** Flag 1 **AND NOT** Flag 2 **AND NOT** Flag 3
- Zone 2 = Flag 1 **AND NOT** Flag 2 **AND NOT** Flag 3
- Zone 3 = Flag 1 **AND** Flag 2 **AND NOT** Flag 3
- Zone 4 = Flag 1 **AND** Flag 2 **AND** Flag 3

As each statement can have only 3 terms in it we must pre-process some part of the equations. The term '**NOT** Flag 2 **AND** **NOT** Flag 3' appears in Zone 1 and 2 equations.

Now we assign valid point numbers to our statements and rewrite them the way they will be input.

First one term needs to be pre-processed to simplify:

$$1025 = \text{NOT Flag 2 AND NOT Flag 3} \qquad 25: /1825\&/1826$$

Next the flow Zones are defined:

$$\text{Zone 1} = \text{NOT Flag 1 AND NOT Flag 2 AND NOT Flag 3} \qquad 26: /1824\&1025$$

$$\text{Zone 2} = \text{Flag 1 AND NOT Flag 2 AND NOT Flag 3} \qquad 27: 1824\&1025$$

$$\text{Zone 3} = \text{Flag 1 AND Flag 2 AND NOT Flag 3} \qquad 28: 1824\&1825\&/1826$$

$$\text{Zone 4} = \text{Flag 1 AND Flag 2 AND Flag 3} \qquad 29: 1824\&1825\&1826$$

The program thus far looks like:

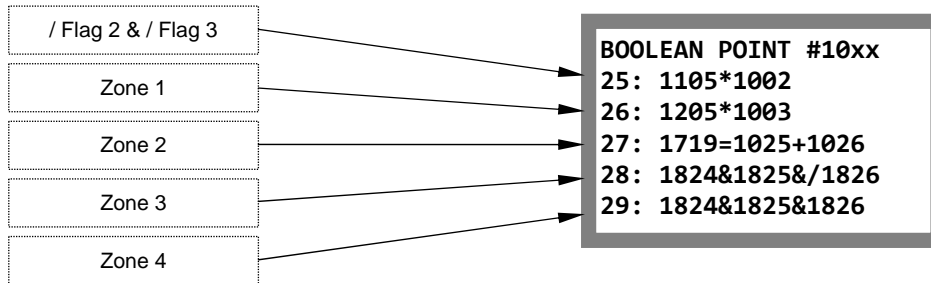

In our example each meter run valve (V1, V2, V3 and V4) fails closed, energizes to open. A limit switch mounted on each valve indicates the fully open position (SW1, SW2, SW3 and SW4).

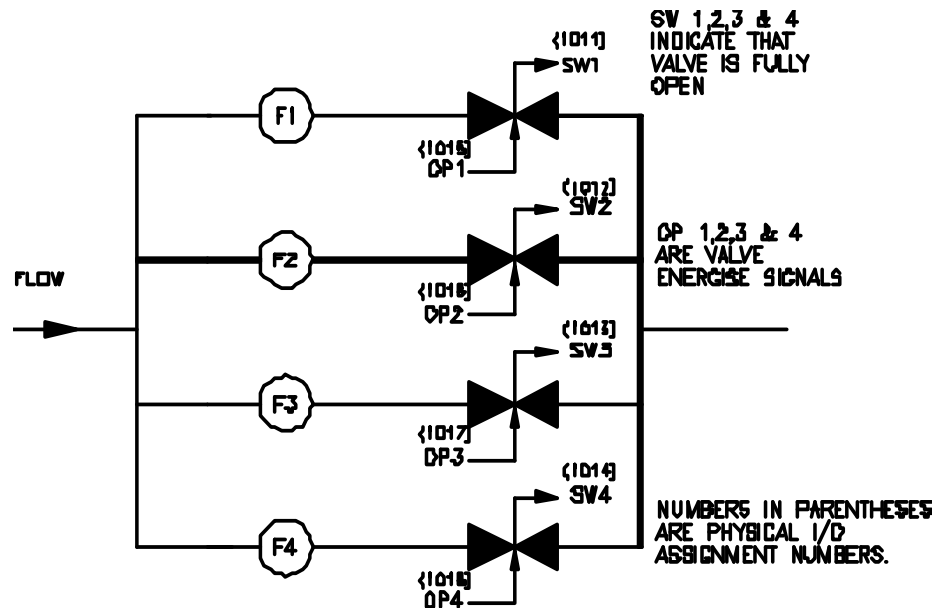

Fig. 3-2. Figure Showing Four-Meter Run Valve Switching

3.2.4. How the Digital I/O Assignments are Configured

We will use Physical I/O Points 11, 12, 13 and 14 to connect to valve limit switches SW1, SW2, SW3 and SW4 respectively. The switches activate when the appropriate valve is fully open. The points are designated as inputs by assigning them to the dummy input Boolean Point 1700 (see the Command and Status Booleans on a later page). Their data base point numbers are simply their I/O point number preceded by 10 (e.g.: I/O Point 11 = 1011).

Physical I/O points 15, 16, 17 and 18 are wired so as to open the meter run valves V1, V2, V3 and V4. They will be assigned to the Boolean Flags 32 (Point 1032) through 35 (Point 1035) which represent the required state of V1 through V4 as explained below.

The Boolean equations are as follows:

$$V1 = (\text{NOT SW2 AND NOT SW3 AND NOT SW4}) \text{ OR Zone 1}$$

Valve #1 is opened when the flow is in Zone 1 and will remain open until at least 1 of the other 3 valves is fully open.

Valves V2, V3 and V4 are programmed in a similar fashion.

$$V2 = (\text{NOT SW1 AND NOT SW3 AND NOT SW4}) \text{ OR Zone 2}$$

$$V3 = (\text{NOT SW1 AND NOT SW2 AND NOT SW4}) \text{ OR Zone 3}$$

$$V4 = (\text{NOT SW1 AND NOT SW2 AND NOT SW3}) \text{ OR Zone 4}$$

To simplify we pre-process the common terms. The term '**NOT SW3 AND NOT SW4**' is used to determine V1 and V2. The term '**NOT SW1 AND NOT SW2**' is used to determine V3 and V4.

Assigning the next valid point numbers to our statements and re-write them the way they will be input.

$$1030 = \text{NOT SW3 AND NOT SW4} \quad 30: /1013\&/1014$$

$$1031 = \text{NOT SW1 AND NOT SW2} \quad 31: /1011\&/1012$$

The final Equations to determine the state of V1, V2, V3 and V4 are as follows:

$$V1 = \text{NOT SW2 AND (NOT SW3 AND NOT SW4) OR Zone 1} \quad 32: /1012\&1030+1026$$

$$V2 = \text{NOT SW1 AND (NOT SW3 AND NOT SW4) OR Zone 2} \quad 33: /1011\&1030+1027$$

$$V3 = (\text{NOT SW1 AND NOT SW2}) \text{ AND NOT SW4 OR Zone 3} \quad 34: 1031\&/1014+1028$$

$$V4 = (\text{NOT SW1 AND NOT SW2}) \text{ AND NOT SW3 OR Zone 4} \quad 35: 1031\&/1013+1029$$

The computer evaluates each expression from left to right, so the order of the variables in the above statements is critical. The logic requires that the **OR** variable comes last.

The final program consists of 11 statements:

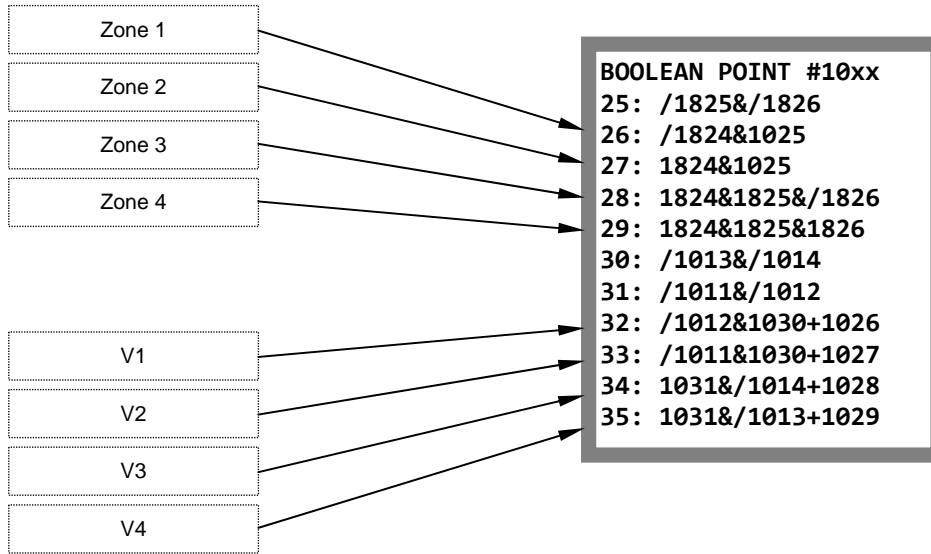

The only thing left to do now is assign Booleans 1032, 1033, 1034 and 1035 to the appropriate digital I/O points which control V1, V2, V3 and V4. Here is a summary of all of the digital I/O as assigned:

PHYSICAL I/O POINT	ASSIGNED TO BOOLEAN	WIRED TO	SYMBOL
11	1700	Valve 1 Fully Open Switch	SW1
12	1700	Valve 2 Fully Open Switch	SW2
13	1700	Valve 3 Fully Open Switch	SW3
14	1700	Valve 4 Fully Open Switch	SW4
15	1032	Valve 1 Actuator	V1
16	1033	Valve 2 Actuator	V2
17	1034	Valve 3 Actuator	V3
18	1035	Valve 4 Actuator	V4

INFO - A list of Modbus database addresses and index numbers is included in **Volume 4** of the OMNI User Manual.

Any pulse signal can be latched by using a small program similar to the following:

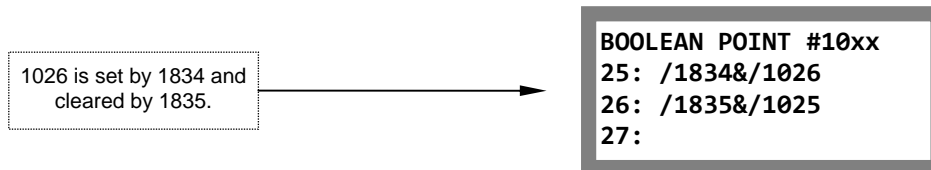

3.3. User Programmable Variables and Statements

There are 64 user-programmable floating point variables within the flow computer numbered 7025 through 7088. The value stored in each of these variables depends on an associated equation or statement. These statements are evaluated every 500 msec and the resultant variable values can be displayed on the LCD display, printed on a report, output to a D-A output, or accessed via one of the communication ports. Typical uses for the variables and statements include providing measurement units conversions, special averaging functions, limit checking and comparisons.

3.3.1. Variable Statements and Mathematical Operators Allowed

Each statement can contain up to 3 variables or constants. The following symbols are used to represent the functions:

TIP - The order of precedence is: ABSOLUTE, POWER, MULTIPLY & DIVIDE, ADD & SUBTRACT. Where operators have the same precedence the order is left to right.

<u>Operator</u>	<u>Symbol</u>	<u>Description</u>
ADD	+	Add the two variables or constants
SUBTRACT	-	Subtract the RH variable or constant from LH
MULTIPLY	*	Multiply the two variables or constants
DIVIDE	/	Divide the two variables or constants
CONSTANT	#	The number following is interpreted as a constant
POWER	&	Raise the LH variable to the power of the RH
ABSOLUTE	\$	Use the abs. unsigned value of variable following
EQUAL	=	Make the variable on left equal to the expression
IF STATEMENT)	Compares the variable to another (What if?)
GOTO STATEMENT	G	Go to a different variable
MOVE RANGE	:	Move statement or result to another variable.
EXACT COMPARE	%	Compare a value with or equal to
TOTALIZE	,	Used to create custom totalizers where Remainders need to be carried into the custom totalizer in the next calculation cycle.
INDIRECT REFERENCE	;	Use the contents of the point following to Determine the address of the target data base point.
WRITE ASCII STRING	“	Write the ASCII string data contained between the quotes to the address to the left of the = sign
RISING EDGE	(Rising Edge Operator eg (7501
FALLING EDGE	(/	Falling Edge Operator eg (/7501
ONE SHOT	@	One Shot Operator eg @7505
RANGE CHECKER	<	Ranger Checking operator

TIP – RH = Right Hand Variable. LH = Left Hand Variable

To program the user variables proceed as follows: From the Display Mode press **[Prog] [Setup] [Enter] [Enter]** and the following menu will be displayed:

```

*** Misc. Setup ***
Password Maint?(Y)
Check Modules ?(Y)
Config Station?(Y)
Config Meter "n"
Config PID ? "n"
Config D/A Out"n"
Front Pnl Counters
Program Booleans ?
Program Variables? _
    
```

Scroll down to **'Program Variables ? (Y)'** and enter **[Y]**. Assuming that no variables are as yet programmed, the display shows:

```

PROG. VARIABLE #70xx
25:  _
26:
27:
    
```

Note that the cursor is on the line labeled 25:. At this point enter the variable equation that will calculate the value of variable 7025.

Example 1:

To provide a variable (7025) which represents Meter Run #1 gross flow rate in 'MCF per day' in place of the usual MCF per hour, multiply the 'MCF per hour' variable (7101) by the constant 24.

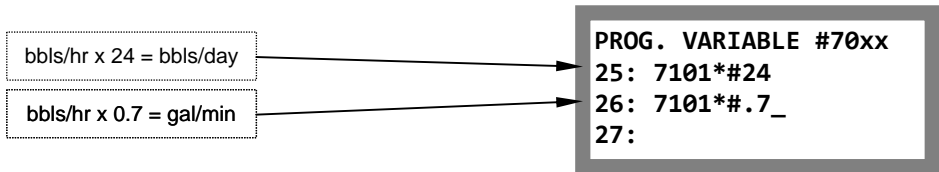

Example 2:

To provide a variable that represents 'gallons per minute' (7026) we can convert the 'barrels per hour' variable (7101) to gallons by multiplying by 0.7 (0.7 = 42/60 which is the number of gallons in a barrel / divided by the number of minutes in an hour).



Example 3:

To provide a variable (7028) that represents meter run #1 temperature in 'degrees Celsius' we subtract 32 from the 'degrees Fahrenheit' variable (7105) and divide the result (7027) by 1.8.

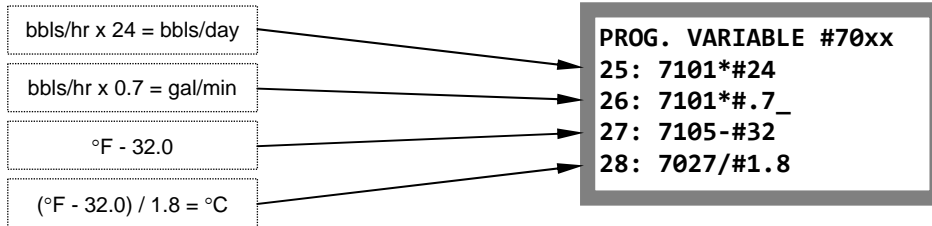

Example 4:

Gross barrels within the flow computer are simply flow meter counts divided by the flow meter 'K-Factor' (pulses per barrel); i.e., gross barrels are not meter factored. To provide a variable (7029) which represents Meter Run #1 gross meter factored barrels, multiply the batch gross barrel totalizer (5101) by the batch flow weighted average meter factor (5114).

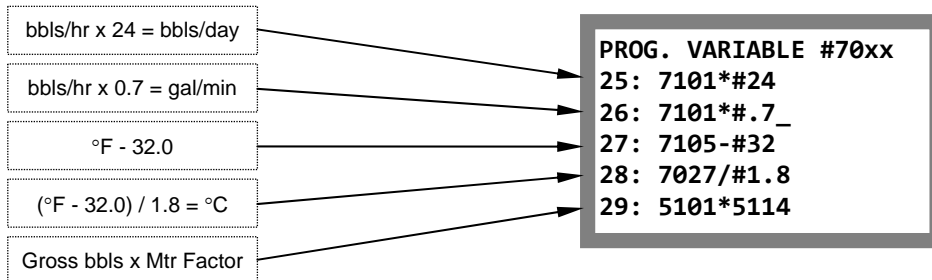

3.3.2. Using Boolean Variables in Variable Statements

Boolean points used in a programmable variable statement are assigned the value 1.0 when the Boolean value is TRUE and 0.0 when the Boolean value is FALSE. By multiplying by a Boolean the user can set a variable to 0.0 when the Boolean point has a value FALSE.

Example:

Provide a variable (7025) which functions as a 'Report Number'. The report number which will appear on each 'batch end report' must increment automatically after each batch and reset to zero at the contract day start hour on January 1 of each year.

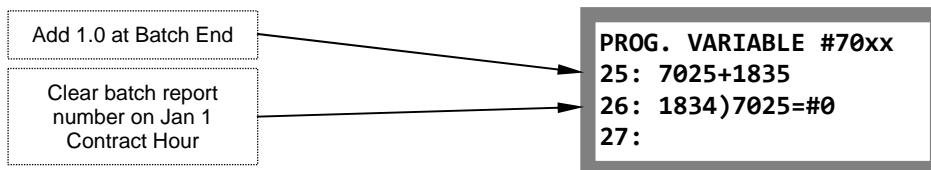

Boolean 1835 is true one calculation cycle at the end of a batch. Boolean point 1834 is equal to 1.0 for one calculation cycle on the contract day start hour on January 1. If statement 1834 is true we reset counter 7025.

3.3.3. Entering Values Directly into the User Variables

In some cases it may be necessary to enter data directly into a user variable (not the expression, just the variable). For example, to preset the 'Report Number' Variable 7025 in the example above we proceed as follows. While in the Display Mode press **[Prog] [Input] [Enter]**, the following will display:

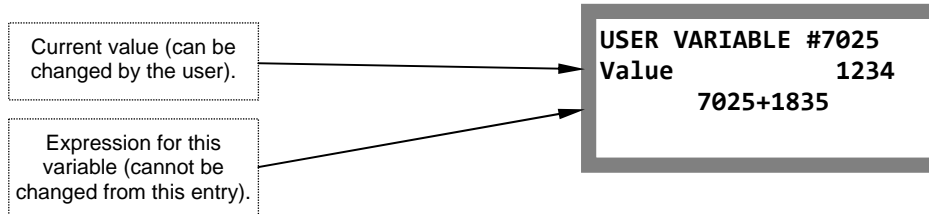

3.3.4. Using the Variable Expression as a Prompt

Entering plain text into the expression associated with the variable causes the computer no problems. It ignores the text and leaves the variable unchanged.

For example:

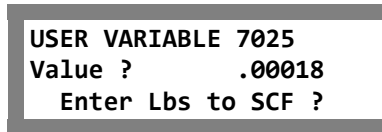

3.3.5. Password Level Needed to Change the Value of a User Variable

The first four variables, 7025, 7026, 7027 and 7028 require 'Level 2' password. the remaining variables require 'Level 1'.

3.3.6. Using Variables in Boolean Expressions

Note: See the beginning of this chapter on how to program a Boolean expression if necessary:

In some cases it is also necessary to trigger some type of an event based on the value of a calculated variable. Boolean variables used in the Boolean expressions and described in the previous text can have only one of two values, ON or OFF (TRUE or FALSE). How can the floating point numbers described in this chapter be used in a Boolean expression? Simply using the fact that a variable can be either positive (TRUE) or negative (FALSE). Any variable or floating point can be used in a Boolean expression.

Example:

Provide an alarm and snapshot report which will occur when the absolute difference in net flow rate between Meter Runs #1 and #2 exceeds 10 bbls/hr, but only when Meter Run #1 flow rate is greater than 1000 bbls/hr.

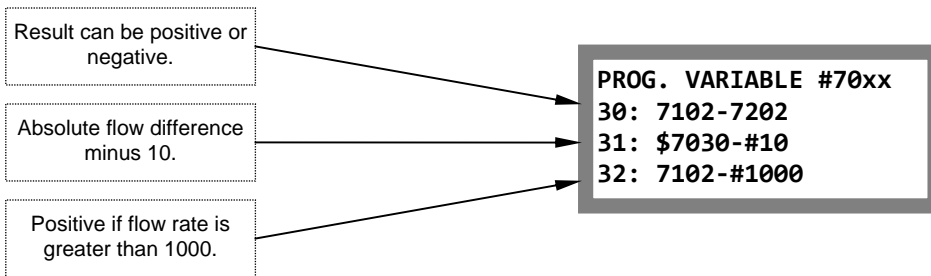

Variable 7031 will be positive (TRUE) if Meter Runs #1 and #2 flow rates differ by more than 10 bbls/hr. Variable 7032 will be positive (TRUE) when Meter Run #1 flow rate exceeds 1000 bbls/hr .

User variables 7031 and 7032 shown above must both be positive for the alarm to be set. In addition, we will require that the condition must exist for 5 minutes to minimize spurious alarms. The alarm will be activated by Physical I/O Point #02 and we will use Boolean statements 1025 and 1026.

Enter the following Boolean statements (1025 and 1026 used as example only):

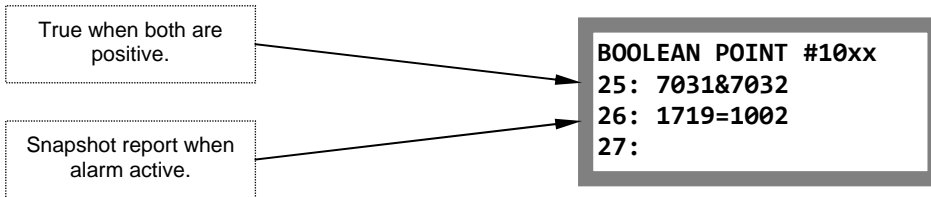

To complete the example we assign Digital I/O Point #02 (Point # 1002) to 1025 and select a 'delay on' of 3000 to provide a 5 minute delay on activate (3000 ticks = 3000 x 100 msec = 300 seconds). Set the 'delay off' to 0.

3.4. User Configurable Display Screens

The user can specify up to eight display screen setups. Each display screen can be programmed to show four variables, each with a descriptive tag. Any variable within the data base can be selected for display.

Steps needed to configure a display screen are:

INFO - The computer checks for the user display key presses first so you may override an existing display screen by selecting the same key press sequence.

- 1) Specify a sequence of up to four key presses that will be used to recall the display. Key presses are identified by the A through Z character on each key. For each variable (four maximum):
- 2) Specify the eight character string to be used to identify the variable. Any valid characters on the keypad can be used.
- 3) Specify the database index or point number.
- 4) Specify the display resolution of the variable (i.e., how many digits to the right of the decimal point).

Should the number exceed the display capacity, the decimal will be automatically shifted right to counter the overflow. The computer will shift to scientific display mode if the integer part of the number exceeds +/- 9,999,999.

To configure the user display screens proceed as follows:

From the Display Mode press **[Prog] [Setup] [Enter] [Enter]** and the following menu will be displayed:

```

*** Misc. Setup ***
Password Maint?(Y)
Check Modules?(Y)
Config Station?(Y)
Config Meter "n"
Config PID ? "n"
Config D/A Out"n"
Front Pnl Counters
Program Booleans ?
Program Variables?
User Display ? "n" _

```

Scroll down to 'User Display ? "n"' and enter 1 through 8 to specify which screen you wish to configure.

The screen for Display #1 shows:



Use the 'UP/DOWN' arrows to scroll through the screen. For 'Key Press' enter the key press sequence (up to 4 keys) that will be used to recall this display. The keys are identified by the letters A through Z.

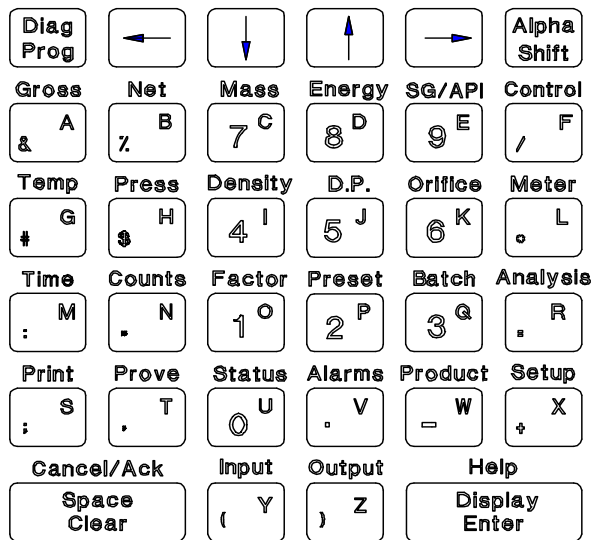

Fig. 3-3. Keypad Layout - A through Z Keys

Example:

You wish to recall 'User Display #1' by pressing **[Gross] [Meter] [1]**, select the key sequence **[A] [L] [O]** as shown below.

```

USER DISPLAY #1
Key Press A L O
Var #1 Tag
Var #1 Index
Var #1 Dec.
    
```

Continue configuring User Display #1 by entering the description tag, index number and decimal position required for each variable.

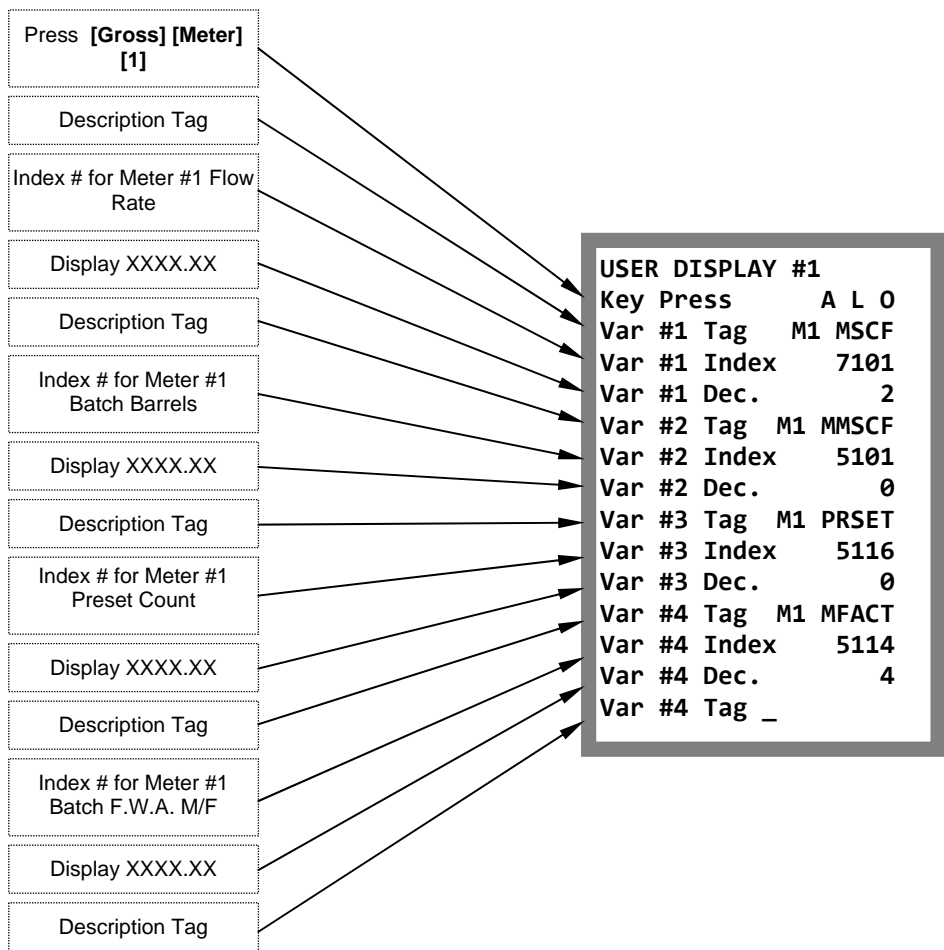

In the preceding example, User Display #1 is used to display Meter Run #1:

Variable #1	Flow rate in MSCF per Hour
Variable #2	Accumulated Batch MSCF
Variable #3	Meter Factor for the Batch
Variable #4	Not Used

The screen is recalled by pressing **[Gross] [Meter] [1] [Enter]** and displays:

USER DISPLAY # 1		
M1 MSCF		1234.56
M1 MMSCF		123456789
M1 MFACT		1.0000

Chapter 4

Flow Equations and Algorithms for US Customary Units (Revision 22.74+)

4.1. Liquid Flow Rate for Flowmeters

The calculations performed for liquid helical turbine, positive displacement and mass flowmeters are as follows:

4.1.1. Volumetric Flow Rate at Flowing Conditions 'Q_v' (Bbls/hr)

$$Q_{v(fv)} = \frac{f_{Hz}}{K_{Fnom}} \times 3600$$

4.1.2. Volumetric Flow Rate at Base Conditions 'Q_b' (Bbls/hr)

$$Q_{b(esv)} = Q_{v(fv)} \times V_{CF} \times C_{PL} \times M_F$$

$$Q_{b(NSV)} = Q_{b(esv)} \times C_{S\&W}$$

4.1.3. Mass Flow Rate 'Q_m' (KLbs/hr)

$$Q_m = \frac{Q_{v(fv)} \times \rho_F \times M_F}{1000}$$

$$Q_m = \frac{Q_{v(esv)} \times \rho_b}{1000}$$

4.1.4. Nomenclature

$Q_{V(IV)}$ = gross indicated volumetric flow rate at flowing conditions, in barrels per hour (Bbls/hr)

$Q_{b(GSV)}$ = gross standard volumetric flow rate at base conditions, in barrels per hour (Bbls/hr)

$Q_{b(NSV)}$ = net standard volumetric flow rate at base conditions, in barrels per hour (Bbls/hr)

Q_m = mass flow rate at flowing conditions for gas turbine flowmeters, in thousands of pounds mass per hour (Klbm/hr)

f_{Hz} = total number of pulses emitted from the flowmeter pulse train per second.

$K_{F_{nom}}$ = nominal K factor, in pulses per barrel (f_{Hz}/Bbl) —supplied by the flow transmitter manufacturer

M_F = meter factor in use (dimensionless)

V_{CF} = volume correction factor (dimensionless —see **5.2.2** this chapter)

C_{PL} = correction factor for pressure on liquid (dimensionless —see **5.2.3** this chapter)

$C_{S\&W}$ = correction factor for percent of sediment and water (%S&W) content in fluid (dimensionless —see **5.2.4** this chapter)

ρ_f = fluid (live) density at flowing conditions (actual temperature and pressure), in gm/cc (see **5.3** this chapter)

ρ_b = calculated reference density at base conditions (standard or reference temperature and pressure), in gm/cc

= relative density at 60°F and equilibrium pressure multiplied by the weight in pounds of one cubic foot water at 60°F and 14,696 pounds per square inch absolute (PSIa)

4.2. Correction Factors for Liquid Flow

Dimensionless Values -
The calculated correction factors for liquid flow equations are dimensionless; however, consistent units must be used when applicable.

The flow rate equations for flowmeters require calculating the following correction factors:

- θ Meter Factor in Use 'M_F'
- θ Volume Correction Factor 'V_{CF}'
- θ Correction Factor for Pressure on Liquid 'C_{PL}'
- θ Correction Factor for Sediment and Water Content 'C_{S&W}'

4.2.1. Meter Factor in Use 'M_F'

$$M_F = M_{F_{BC}} + M_{F_{PO}}$$

Where:

M_F = meter factor in use (dimensionless)

M_{F_{BC}} = meter factor interpolated from base meter factor curve

M_{F_{PO}} = meter factor offset from base meter factor curve obtained from proving

4.2.2. Volume Correction Factor 'V_{CF}'

$$V_{CF} = e \left(-\alpha T \times \Delta T \times \left[1 + \left(0.8 \times \alpha T_r \times \Delta T \right) \right] \right)$$

Where:

V_{CF} = volume correction factor

e = Napierian constant
= 2.71828

αT_r = correction for expansion at reference temperature

$$= \frac{K_0 + (K_1 \times RHO_{Tr})}{(RHO_{Tr})^2}$$

Where:

K₀ & K₁ = physical constants derived from mathematical data published in the API MPMS, as follows:

Product Type	Crude Oil	Fuel Oil	Jet Group	Gasoline
API Tables	6A, 23A	6B, 23B	6B, 23B	6B, 23B
API Gravity Range	0° to 100°	0° to 37°	37.1° to 47.9°	52.1° to 85°
Relative Density Range	0.6110 to 1.0760	0.8400 to 1.0760	0.7890 to 0.8395	0.6535 to 0.7705
K ₀	341.0957	103.8720	330.3010	192.4571
K ₁	0	0.2701	0	0.2438

RHO_{Tr} = product density at reference temperature

$$= \frac{141.5 \times \rho_{H_2O}}{API_{60} + 131.5}$$

Where:

ρ_{H_2O} = density of water

API₆₀ = API gravity, in degrees

When Product is between Jet Group and Gasoline:

$$\alpha T_r = A + \frac{B}{(RHO_{Tr})^2}$$

Where:

A & B are numerical constants obtained from API Standards as follows:

Between Jet & Gasoline	
API Tables	6B, 24B, 5B, 23B
API Gravity Range	48.0° to 52.0°
Relative Density Range	0.7710 to 0.7885
A	-0.0018684
B	1489.067

ΔT = differential temperature

$$= T_a - T_r$$

Where:

T_a = actual temperature, in °F

T_r = reference temperature, in °F

4.2.3. Correction Factor for Pressure on Liquid 'C_{PL}'

$$C_{PL} = \frac{1}{1 - (P - P_e) \times F}$$

Where:

C_{PL} = correction factor for pressure on liquid (dimensionless)

P = flowing pressure in pounds per square inch gauge (PSig)

P_e = equilibrium vapor pressure calculated from the correlations developed by Dr. R. W. Hankinson, et al., of Phillips Petroleum Company for members of the GPA, and published as GPA Technical Publication N^o 15.

F = Compressibility factor for hydrocarbons; using API MPMS 11.2.1 for liquids 0 to 90 API relative density; and using API MPMS 11.2.2 for hydrocarbons ranging 0.35 to 0.637 relative density and -50°F to 140°F.

4.2.4. Correction Factor for Sediment and Water Content 'C_{S&W}'

$$C_{S\&W} = 1 - \frac{\%S\&W}{100}$$

Where:

$C_{S\&W}$ = correction factor for percent of sediment and water (%S&W) content in fluid (dimensionless)

%S&W = percent of sediment and water content in fluid

4.3. Densities and Other Properties of Liquids

The flow rate equations for flowmeters require determining the following densities and other properties:

- θ Flowing Density ' ρ_f ' for Crude Oil and Refined Products
- θ Density of Ethane, Propane and Methane Mixes
- θ Density of Water
- θ Density and Relative Density (Specific Gravity) Calculated from Live Digital Densitometer Output Frequency

4.3.1. Flowing Density ' ρ_f ' for Crude Oil and Refined Products

$$\rho_f = \rho_b \times V_{CF} \times C_{PL}$$

Where:

ρ_f = fluid density at flowing conditions (actual temperature and pressure), in gm/cc

ρ_b = fluid density at base conditions (standard/reference temperature and pressure), in gm/cc

= relative density at 60°F and equilibrium pressure multiplied by the weight in pounds of one cubic foot water at 60°F and 14,696 pounds per square inch absolute (PSIa)

V_{CF} = volume correction factor (ASTM D1250)

C_{PL} = correction factor for pressure on liquid

4.3.2. Density and Relative Density (Specific Gravity) Calculated from Live Digital Densitometer Output Frequency

Density and Relative Density Values Determined from Densitometer and Gravitometer Frequency Signals - The equations used to determine the density and relative density via density transducers are provided by the respective manufacturers.

The calculations expressed in this section are performed by the OMNI to determine the density from frequency signals received from the following third party densitometers and gravimeters:

- θ Sarasota™ / Peek™
- θ UGC™
- θ Solartron™

Densitometer Calibration Constants - In many cases the densitometer constants supplied by the manufacturers are based on SI or metric units. You must ensure that the constants entered are based on grams/cc, °F and PSig. Contact the densitometer manufacturer or OMNI if you require assistance.

Sarasota Density (gm/cc)

Sarasota density is calculated using the frequency signal produced by a Sarasota densitometer, and applying temperature and pressure corrections as shown below:

$$D_c = D_{CF} \times \frac{D_0' (t - t_0')}{t_0'} \times \frac{2 + K (t - t_0')}{t_0'}$$

Where:

D_c = corrected density

D_{CF} = Density correction factor

D_0' = calibration constant, in mass/volume*

t = densitometer oscillation period in microseconds (μsec)

t_0 = calibration constant, in microseconds

$t_0' = T_{coef} \times (T_f - T_{cal}) + P_{coef} \times (P_f - P_{cal}) + t_0$

where:

T_f = flowing temperature, in °F

T_{coef} = temperature coefficient, in μsec/°F

P_f = flowing pressure, in PSig

P_{coef} = pressure coefficient, in μsec/PSig

P_{cal} = calibration pressure, in PSig

K = spool calibration constant

Note:

* D_0' must be expressed in pounds per cubic foot (gm/cc).

Density and Relative Density Values Determined from Densitometer and Gravimeter Frequency Signals - The equations used to determine the density and relative density via density transducers are provided by the respective manufacturers.

UGC Density (grams/cc)

UGC density is calculated using the frequency signal produced by a UGC densitometer, and applying temperature and pressure corrections as shown below:

UNCORRECTED DENSITY:

$$D = K_0 + (K_1 \times t) + (K_2 \times t^2)$$

Where:

D = uncorrected density, in grams/cc

$\left. \begin{matrix} K_0 \\ K_1 \\ K_2 \end{matrix} \right\}$ = calibration constants of density probe, entered via the keypad

t = densitometer oscillation time period, in microseconds (μsec)

CORRECTED DENSITY:

$$D_c = D_{CF} \times \left\{ \left[\left(K_{P_3} D^2 + K_{P_2} D + K_{P_1} \right) \times (P_f - P_c) \right] + \left[\left(K_{t_3} D^2 + K_{t_2} D + K_{t_1} \right) \times (T_f - T_c) \right] + D \right\}$$

Where:

D_c = corrected density, in grams/cc

D_{CF} = density correction factor

D = uncorrected density, in grams/cc

$\left. \begin{matrix} K_{P_1} \\ K_{P_2} \\ K_{P_3} \end{matrix} \right\}$ = pressure constants

P_f = flowing pressure, in PSIG

P_c = calibration pressure, in PSIG

$\left. \begin{matrix} K_{t_1} \\ K_{t_2} \\ K_{t_3} \end{matrix} \right\}$ = temperature constants

T_f = flowing temperature, in °F

T_c = calibration temperature, in °F

Densitometer Calibration Constants - In many cases the densitometer constants supplied by the manufacturers are based on SI or metric units. You must ensure that the constants entered are based on grams/cc, °F and PSig. Contact the densitometer manufacture or OMNI if you require assistance.

Solartron™ Density (grams/cc)

Solartron™ density is calculated using the frequency signal produced by a Solartron frequency densitometer, and applying temperature and pressure corrections as detailed below.

UNCORRECTED DENSITY:

$$D = K_0 + (K_1 \times t) + (K_2 \times t^2)$$

Where:

D = uncorrected density, in grams/cc

$\left. \begin{matrix} K_0 \\ K_1 \\ K_2 \end{matrix} \right\}$ = calibration constants supplied by Solartron, in grams/cc and °F

t = densitometer oscillation time period, in microseconds (µsec)

TEMPERATURE COMPENSATED DENSITY:

$$D_T = D \times [1 + K_{18} (T_f - 68)] + [K_{19} (T_f - 68)]$$

Where:

D_T = temperature corrected density, in grams/cc

D = uncompensated density, in grams/cc

$\left. \begin{matrix} K_{18} \\ K_{19} \end{matrix} \right\}$ = calibration constants supplied by Solartron

T_f = Temperature in °F

TEMPERATURE AND PRESSURE COMPENSATED DENSITY:

$$D_{PT} = D_T \times [1 + (K_{20} \times P_f) + (K_{21} \times P_f)]$$

Where:

D_{PT} = temperature and pressure compensated density, in grams/cc

D_T = temperature compensated density, in grams/cc

$$K_{20} = K_{20A} + (K_{20B} \times P_f)$$

$$K_{21} = K_{21A} + (K_{21B} \times P_f)$$

$\left. \begin{matrix} K_{20A} \\ K_{20B} \\ K_{21A} \\ K_{21B} \end{matrix} \right\}$ = calibration constants supplied by Solartron

P_f = flowing pressure in PSig

Additional Density Equation for Velocity of Sound Effects:

For LPG Products in the range of 0.350 - 0.550 grams/cc, the following term can be applied to the temperature and pressure compensated density 'D_{tp}':

$$D_{VOS} = D_{tp} + K_r (D_{tp} - K_j)^3$$

Where:

D_{VOS} = density for velocity of sound effects, in grams/cc

D_{tp} = temperature and pressure compensated density, in grams/cc

$\left. \begin{array}{l} K_r \\ K_j \end{array} \right\}$ = calibration constants supplied by Solartron

Users wishing to implement the above term are advised to contact Solartron™ to obtain a reworked calibration sheet containing the coefficients 'K_r' and 'K_j'. (Typically, K_r = 1.1 and K_j = 0.5). If you do not want to implement the above term, enter 0.0 for K_r.

4.4. Recalculation of Batch Ticket

The actual values of API₆₀ and %S&W that correspond to a batch are obtained after the batch has ended. The option to recalculate the batch ticket adjusts the batch quantities to actual results when the new, actual values of API₆₀ and %S&W are entered. The calculations performed are:

- θ Recalculated Gross Standard Volume
- θ Recalculated Net Standard Volume
- θ Factored Gross Volume
- θ Net Weight Delivered

4.4.1. Recalculated Gross Standard Volume 'GSV_{Recalc}' (Bbls)

$$GSV_{Recalc} = BGF \times V_{CF_a} \times C_{PL_a} \times \overline{M_F}$$

Where:

GSV_{Recalc} = recalculated gross standard volume, in barrels (Bbls)

BGF = batch gross volume

V_{CF_a} = recalculated volume correction factor (correction for temperature on liquid; ASTM D1250) using batch average temperature and entered (actual) API_{60a} (see 5.2.2 this chapter)

C_{PL_a} = recalculated correction factor for pressure on liquid using batch average pressure and entered (actual) API_{60a} (see 5.2.3 this chapter)

$\overline{M_F}$ = average meter factor (see 5.2.1 this chapter)

4.4.2. Recalculated Net Standard Volume

Recalculated Net Standard Volume in US Customary Units 'NSV' (Bbls)

$$NSV_{Recalc} = GSV_{Recalc} \times C_{S\&W_a}$$

Where:

NSV_{Recalc} = recalculated net standard volume at 60°F and 0 PSIG, in barrels (Bbls)

GSV_{Recalc} = recalculated gross standard volume, in barrels (Bbls)

$C_{S\&W_a}$ = actual correction factor for percent of sediment and water (%S&W) content in fluid (dimensionless)

Recalculated Net Standard Volume in Metric Units 'Nm³' (m³)

$$\text{Nm}^3_{\text{Recalc}} = \text{NSV}_{\text{Recalc}} \times C_{\text{API}_{60}}$$

Where:

$\text{Nm}^3_{\text{Recalc}}$ = recalculated net standard volume at 15°C and 101.325 kPa, in cubic meters (m³)

$C_{\text{API}_{60}}$ = correction factor for API₆₀ (see table below)

API ₆₀	C _{API₆₀}
0.0 - 12.0	0.15893
12.1 - 31.4	0.15892
31.5 - 44.2	0.15891
44.3 - 52.4	0.15890
52.5 - 59.9	0.15889
60.0 - 68.7	0.15888

4.4.3. Factored Gross Volume 'FGV' (Bbls)

$$\text{FGV} = \text{BGF} \times \overline{M}_F$$

Where:

FGV = factored gross volume, in barrels (Bbls)

BGF = batch gross flow rate, in barrels per hour (Bbls/hr)

\overline{M}_F = average meter factor (see 5.2.1 this chapter)

4.4.4. Net Weight Delivered 'NWD'

$$\text{NWD}_{(\text{l-ton})} = \text{NSV}_{\text{Recalc}} \times 0.0375 \times \left(\frac{589.9483}{\text{API}_{60} + 131.5} - 0.0050789 \right)$$

$$\text{NWD}_{(\text{m-ton})} = \text{NWD}_{(\text{l-ton})} \times 1.01605$$

Where:

$\text{NWD}_{(\text{l-ton})}$ = net weight delivered, in US customary units (long tons)

$\text{NWD}_{(\text{m-ton})}$ = net weight delivered, in metric units (metric tons)

$\text{NSV}_{\text{Recalc}}$ = recalculated net standard volume at 60°F and 0 PSIG, in barrels (Bbls)

4.5. Liquid Flow Rate for Provers

The calculations performed for unidirectional, bi-directional and small volume (compact) provers are as follows:

4.5.1. Prove Gross Flow Rate at Flowing Conditions (Bbls/hr)

Gross Flow Rate for Uni- and Bi-directional Provers 'PQ_{v(U/B)}'

$$PQ_{v(U/B)} = \frac{Pf_{Hz}}{K_{Fnom}} \times 3600$$

Gross Flow Rate for Small Volume (Compact) Provers 'PQ_{v(SVP)}'

$$PQ_{v(SVP)} = \frac{PV_b}{Td_{vol}} \times 3600$$

4.5.2. Prove Flow Rate using Pulse Interpolation Method

$$\text{Prove Interpoated Counts} = \text{Integer Counts} \left(\frac{Td_{vol}}{Td_{fmp}} \right)$$

4.5.3. Nomenclature

$PQ_{V(U/B)}$ = prove gross flow rate at flowing conditions for uni- and bi-directional provers, in barrels per hour (Bbls/hr)

$PQ_{V(SVP)}$ = prove gross flow rate at flowing conditions for small volume (compact) provers, in barrels per hour (Bbls/hr)

PV_b = base prover volume at 60°F and 0 PSig, in barrels (Bbls)

Pf_{Hz} = total number of flow pulses per second during the prove

$K_{F_{nom}}$ = nominal K factor, in pulses per barrel (f_{Hz}/Bbl) —supplied by the flow transmitter manufacturer

Td_{vol} = timer pulses accumulated between detectors switches (each pulse is 200 nanoseconds)

Td_{fmp} = timer pulses accumulated between first flow pulse after each detector switches (each pulse is 200 nanoseconds)

4.5.4. Meter Factors for Provers

Prove Meter Factor 'PM_F'

$$PM_F = \frac{PV_b \times C_{TSP} \times C_{PSP} \times C_{TLP} \times C_{PLP}}{\frac{Pf}{K_F} \times C_{TLM} \times C_{PLM}}$$

Where:

PM_F = prove meter factor (dimensionless)

PV_b = base prover volume at 60°F and 0 PSig, in barrels (Bbls)

Pf = number of flow pulses during the prove

C_{TSP} = correction factor for effects of temperature on steel at the prover

For Uni- and Bi-directional Provers:

$$C_{TSP} = 1 + [(\bar{T} - \bar{T}_b) \times t_{coef}]$$

Where:

\bar{T} = average prover temperature, in °F

\bar{T}_b = average base prover temperature, in °F

t_{coef} = coefficient of cubical expansion per °F of the prover tube

For Small Volume (Compact) Provers:

$$C_{TSP} = \left(1 + [(\bar{T} - \bar{T}_b) \times t_{coef_P}] \right) \times \left(1 + [(\bar{T}_i - \bar{T}_b) \times t_{coef_i}] \right)$$

Where:

\bar{T} = average prover temperature, in °F

\bar{T}_i = average prover switch rod temperature, in °F

\bar{T}_b = average base prover temperature, in °F

t_{coef_P} = square coefficient of expansion per °F of the prover tube

t_{coef_i} = linear coefficient of cubical expansion per °F of the prover switch rod

C_{PSP} = correction factor for effects of pressure on steel at the prover

$$= 1 + \frac{(P - P_b) \times D}{E \times t}$$

Where:

P = internal prover pressure, in PSIG

P_b = base prover pressure, in PSIG

D = internal prover tube diameter, in inches

E = modulus of elasticity for prover tube

t = wall thickness of prover tube, in inches

C_{TLP} = correction factor for effects of temperature on liquid (volume correction factor) at the prover

= volume correction factor ' V_{CF} ', where the actual temperature ' T_a ' is replaced by the average temperature during the prove, at the prover (see 5.2.2 this chapter)

C_{PLP} = correction factor for effects of pressure on liquid at the prover

= correction factor for pressure on liquid ' C_{PL} ', where the flowing pressure ' P ' is replaced by average pressure during the prove, at the prover (see 5.2.3 this chapter)

C_{TLM} = correction factor for effects of temperature on liquid (volume correction factor) at the flowmeter

= volume correction factor ' V_{CF} ', where the actual temperature ' T_a ' is replaced by the average temperature during the prove, at the flowmeter (see 5.2.2 this chapter)

C_{PLM} = correction factor for effects of pressure on liquid at the flowmeter

= correction factor for pressure on liquid ' C_{PL} ', where the flowing pressure ' P ' is replaced by average pressure during the prove, at the flowmeter (see 5.2.3 this chapter)

Prove Meter Factor at Base Prove Flow Rate 'PM_{F_{PQ_b}}'

$$PM_{F_{PQ_b}} = PM_F + \left(M_{F_{BCPQ_b}} - M_{F_{BCPQ_v}} \right)$$

Where:

$M_{F_{PQ_b}}$ = meter factor at base prove flow rate

PM_F = prove meter factor

$M_{F_{BCPQ_b}}$ = meter factor interpolated from base flowmeter factor curve, using base prove flow rate

$M_{F_{BCPQ_v}}$ = meter factor interpolated from base flowmeter factor curve, using actual prove flow rate

Meter Factor Offset from Base Curve Obtained from Proving 'M_{F_{PO}}'

$$M_{F_{PO}} = M_{F_{PQ_b}} - M_{F_{BCPQ_b}}$$

Where:

$M_{F_{PO}}$ = meter factor offset from base meter factor curve obtained from proving

$M_{F_{PQ_b}}$ = meter factor at base prove flow rate

$M_{F_{BCPQ_b}}$ = meter factor interpolated from base flowmeter factor curve, using base prove flow rate

4.6. Calculations for PID Control

4.6.1. Primary Variable Error % 'e_p'

Forward Action

$$e_p = \text{Primary Setpoint \% Span} - \text{Primary Variable \% Span}$$

Reverse Action

$$e_p = \text{Primary Variable \% Span} - \text{Primary Setpoint \%}$$

4.6.2. Secondary Variable Error % 'e_s'

Forward Action

$$e_s = \text{Secondary Gain} \times (\text{Sec. Setpoint \% Span} - \text{Sec. Variable \% Span})$$

Reverse Action

$$e_s = \text{Secondary Gain} \times (\text{Sec. Variable \% Span} - \text{Sec. Setpoint \% Span})$$

4.6.3. Control Output % 'C₀' (Before Startup Limit Function)

Controlling on Primary Variable

$$C_0 = \text{Primary Gain} \times (e_p + \sum e)$$

Controlling on Secondary Variable

$$C_0 = \text{Primary Gain} \times (e_s + \sum e)$$

4.6.4. Integral Error ' Σe '

Controlling on Primary Variable

$$\Sigma e = (\text{Repeats per Minute of Primary Variable} \times \text{Sample Period} \times e_p) + \Sigma e_{n-1}$$

Controlling on Secondary Variable

$$\Sigma e = (\text{Repeats per Minute of Sec Variable} \times \text{Sample period} \times e_s) + \Sigma e_{n-1}$$

Chapter 5

Flow Equations and Algorithms for SI (Metric) Units (Revision 26.74+)

5.1. Liquid Flow Rate for Flowmeters

The calculations performed for liquid helical turbine, positive displacement and mass flowmeters are as follows:

5.1.1. Volumetric Flow Rate at Flowing Conditions 'Q_v' (m³/hr)

$$Q_{v(IV)} = \frac{f_{Hz}}{K_{Fnom}} \times 3600$$

5.1.2. Volumetric Flow Rate at Base Conditions 'Q_b' (m³/hr)

$$Q_{b(GSV)} = Q_{v(IV)} \times V_{CF} \times C_{PL} \times M_F$$

5.1.3. Mass Flow Rate 'Q_m' (Ton/hr)

$$Q_m = \frac{Q_{v(IV)} \times \rho_f \times M_F}{1000}$$

$$Q_m = \frac{Q_{v(GSV)} \times \rho_b}{1000}$$

5.1.4. Nomenclature

$Q_{V(IV)}$ = gross indicated volumetric flow rate at flowing conditions, in cubic meters per hour (m^3/hr)

$Q_{b(GSV)}$ = gross standard volumetric flow rate at base conditions, in cubic meters per hour (m^3/hr)

Q_m = mass flow rate at flowing conditions for gas turbine flowmeters, in ton per hour (ton/hr)

f_{Hz} = total number of pulses emitted from the flowmeter pulse train per second.

$K_{F_{nom}}$ = nominal K factor, in pulses per cubic meter (f_{Hz}/m^3) —supplied by the flow transmitter manufacturer

M_F = meter factor in use (dimensionless)

V_{CF} = volume correction factor (dimensionless —see **6.2.2** this chapter)

C_{PL} = correction factor for pressure on liquid (dimensionless —see **6.2.3** this chapter)

ρ_f = fluid (live) density at flowing conditions (actual temperature and pressure), in kilograms per cubic meter (Kgs/m^3 —see **6.3** this chapter)

ρ_b = calculated reference density at base conditions (standard or reference temperature and pressure), kilograms per cubic meter (Kgs/m^3 at 15°F and equilibrium pressure)

5.2. Correction Factors for Liquid Flow

Dimensionless Values -
The calculated correction factors for liquid flow equations are dimensionless; however, consistent units must be used when applicable.

The flow rate equations for flowmeters require calculating the following correction factors:

- θ Meter Factor in Use 'M_F'
- θ Volume Correction Factor 'V_{CF}'
- θ Correction Factor for Pressure on Liquid 'C_{PL}'
- θ Correction Factor for Sediment and Water Content 'C_{S&W}'

5.2.1. Meter Factor in Use 'M_F'

$$M_F = M_{F_{BC}} + M_{F_{PO}}$$

Where:

M_F = meter factor in use (dimensionless)

M_{F_{BC}} = meter factor interpolated from base meter factor curve

M_{F_{PO}} = meter factor offset from base meter factor curve obtained from proving

5.2.2. Volume Correction Factor 'V_{CF}'

$$V_{CF} = e \left(-\alpha T_r \times \Delta T \times \left[1 + \left(0.8 \times \alpha T_r \times \Delta T \right) \right] \right)$$

Where:

V_{CF} = volume correction factor

e = Napierian constant
= 2.71828

αT_r = correction for expansion at reference temperature
= $\frac{K_0 + (K_1 \times RHO_{Tr})}{(RHO_{Tr})^2}$

Where:

K₀ & K₁ = physical constants derived from mathematical data published in the API MPMS, as follows:

Product Type	Crude Oil	Fuel Oil	Jet Group	Gasoline
API Table	54A	54B	54B	54B
Density Range in Kgs/m ³	610.5 to 1075	839 to 1075	788 to 838.5	653 to 771
K ₀	613.9723	186.9696	594.5418	346.4228
K ₁	0	0.4862	0	0.4388

RHO_{Tr} = product density at reference temperature

When Product is between Jet Group and Gasoline:

$$\alpha T_r = A + \frac{B}{(RHO_{Tr})^2}$$

Where:

A & B are numerical constants obtained from API Standards as follows:

Between Jet & Gasoline	
API Tables	54B
Density Range (Kgs/m ³)	770.5 to 787.5
A	-0.00336312
B	2680.3206

$$\begin{aligned}\Delta T &= \text{differential temperature} \\ &= T_a - T_r\end{aligned}$$

Where:

T_a = actual temperature, in °C

T_r = reference temperature, in °C

5.2.3. Correction Factor for Pressure on Liquid 'C_{PL}'

$$C_{PL} = \frac{1}{1 - (P - P_e) \times F}$$

Where:

C_{PL} = correction factor for pressure on liquid (dimensionless)

P = flowing pressure in kiloPascals gauge (kPag)

P_e = equilibrium vapor pressure calculated from the correlations developed by Dr. R. W. Hankinson, et al., of Phillips Petroleum Company for members of the GPA, and published as GPA Technical Publication N^o 15.

F = Compressibility factor for hydrocarbons; using API Chapter 11.2.1M for Crude Oil (638 to 1075 kg/m³ density, -30°C to 90°C), using API Chapter 11.2.2M for Hydrocarbon Products (350-637 kg/m³ density, -46°C to 60°C).

5.3. Densities and Other Properties of Liquids

The flow rate equations for flowmeters require determining the following densities and other properties:

- θ Flowing Density ' ρ_f ' for Crude Oil and Refined Products
- θ Density of Ethane, Propane and Methane Mixes
- θ Density and Relative Density (Specific Gravity) Calculated from Live Digital Densitometer Output Frequency

5.3.1. Flowing Density ' ρ_f ' for Crude Oil and Refined Products

$$\rho_f = \rho_b \times V_{CF} \times C_{PL}$$

Where:

ρ_f = fluid density at flowing conditions (actual temperature and pressure), in kilograms per cubic meter (Kgs/m³)

ρ_b = fluid density at base conditions (standard/reference temperature and pressure), in kilograms per cubic meter (Kgs/m³)
= density at 15°C and equilibrium pressure

V_{CF} = volume correction factor (ASTM D1250)

C_{PL} = correction factor for pressure on liquid

5.3.2. Density of Ethane, Propane and C3+ Mixes

The density of these mixes at flowing temperature and pressure is calculated from a computer algorithm developed by Phillips Petroleum (August 1992). The algorithm was based on data published in GPA TP1, TP2 and TP5.

5.3.3. Density and Relative Density (Specific Gravity) Calculated from Live Digital Densitometer Output Frequency

Density and Relative Density Values Determined from Densitometer and Gravitometer Frequency Signals - The equations used to determine the density and relative density via density transducers are provided by the respective manufacturers.

The calculations expressed in this section are performed by the OMNI to determine the density from frequency signals received from the following third party densitometers and gravimeters:

- θ Sarasota™ / Peek™
- θ UGC™
- θ Solartron™

Densitometer Calibration Constants - In many cases the densitometer constants supplied by the manufacturers are based on SI or metric units. You must ensure that the constants entered are based on Kg/m³, °C and kPa. Contact the densitometer manufacturer or OMNI if you require assistance.

Sarasota Density (Kgs/m³)

Sarasota density is calculated using the frequency signal produced by a Sarasota densitometer, and applying temperature and pressure corrections as shown below:

$$D_c = D_{CF} \times \frac{[D_0' (t - t_0')]}{t_0} \times \frac{[2 + K(t - t_0')]}{t_0}$$

Where:

D_c = corrected density

D_{CF} = Density correction factor

D₀ = calibration constant, in mass/volume*

t = densitometer oscillation period in microseconds (μsec)

t₀ = calibration constant, in microseconds

t₀' = T_{coef} × (T_f - T_{cal}) + P_{coef} × (P_f - P_{cal}) + t₀

where:

T_f = flowing temperature, in °C

T_{coef} = temperature coefficient, in μsec/°C

P_f = flowing pressure, in kPag

P_{coef} = pressure coefficient, in μsec/ kPag

P_{cal} = calibration pressure, in kPag

K = spool calibration constant

Note:

* D₀' must be expressed in kilograms per cubic meter (Kg/m³).

Density and Relative Density Values Determined from Densitometer and Gravimeter Frequency Signals - The equations used to determine the density and relative density via density transducers are provided by the respective manufacturers.

UGC Density (Kgs/m³)

UGC density is calculated using the frequency signal produced by a UGC densitometer, and applying temperature and pressure corrections as shown below:

UNCORRECTED DENSITY:

$$D = K_0 + (K_1 \times t) + (K_2 \times t^2)$$

Where:

D = uncorrected density, in Kgs/m³

$\left. \begin{array}{l} K_0 \\ K_1 \\ K_2 \end{array} \right\}$ = calibration constants of density probe, entered via the keypad

t = densitometer oscillation time period, in microseconds (μsec)

CORRECTED DENSITY:

$$D_c = D_{CF} \times \left\{ \left[\left(K_{P_3} D^2 + K_{P_2} D + K_{P_1} \right) \times (P_f - P_c) \right] + \left[\left(K_{t_3} D^2 + K_{t_2} D + K_{t_1} \right) \times (T_f - T_c) \right] + D \right\}$$

Where:

D_c = corrected density, in Kgs/m³

D_{CF} = density correction factor

D = uncorrected density, in Kgs/m³

$\left. \begin{array}{l} K_{P_1} \\ K_{P_2} \\ K_{P_3} \end{array} \right\}$ = pressure constants

P_f = flowing pressure, in kPag

P_c = calibration pressure, in kPag

$\left. \begin{array}{l} K_{t_1} \\ K_{t_2} \\ K_{t_3} \end{array} \right\}$ = temperature constants

T_f = flowing temperature, in °C

T_c = calibration temperature, in °C

Densitometer Calibration Constants - In many cases the densitometer constants supplied by the manufacturers are based on SI or metric units. You must ensure that the constants entered are based on Kg/m³, °C and kPa. Contact the densitometer manufacture or OMNI if you require assistance.

Solartron™ Density (Kgs/m³)

Solartron™ density is calculated using the frequency signal produced by a Solartron frequency densitometer, and applying temperature and pressure corrections as detailed below.

UNCORRECTED DENSITY:

$$D = K_0 + (K_1 \times t) + (K_2 \times t^2)$$

Where:

D = uncorrected density, in Kgs/m³

$\left. \begin{matrix} K_0 \\ K_1 \\ K_2 \end{matrix} \right\}$ = calibration constants supplied by Solartron, in Kgs/m³ and °C

t = densitometer oscillation time period, in microseconds (µsec)

TEMPERATURE COMPENSATED DENSITY:

$$D_T = D \times [1 + K_{18} (T_f - 20)] + [K_{19} (T_f - 20)]$$

Where:

D_T = temperature corrected density, in Kgs/m³

D = uncompensated density, in Kgs/m³

$\left. \begin{matrix} K_{18} \\ K_{19} \end{matrix} \right\}$ = calibration constants supplied by Solartron

T_f = Temperature in °C

TEMPERATURE AND PRESSURE COMPENSATED DENSITY:

$$D_{PT} = D_T \times [1 + (K_{20} \times P_f) + (K_{21} \times P_f)]$$

Where:

D_{PT} = temperature and pressure compensated density, in Kgs/m³

D_T = temperature compensated density, in Kgs/m³

K₂₀ = K_{20A} + (K_{20B} × P_f)

K₂₁ = K_{21A} + (K_{21B} × P_f)

$\left. \begin{matrix} K_{20A} \\ K_{20B} \\ K_{21A} \\ K_{21B} \end{matrix} \right\}$ = calibration constants supplied by Solartron

P_f = flowing pressure in kPag

Additional Density Equation for Velocity of Sound Effects:

For LPG Products in the range of 350 to 550 Kgs/m³, the following term can be applied to the temperature and pressure compensated density 'D_{tp}':

$$D_{VOS} = D_{tp} + K_r (D_{tp} - K_j)^3$$

Where:

D_{VOS} = density for velocity of sound effects, in Kgs/m³

D_{tp} = temperature and pressure compensated density, in Kgs/m³

$\left. \begin{array}{l} K_r \\ K_j \end{array} \right\} =$ calibration constants supplied by Solartron

Users wishing to implement the above term are advised to contact Solartron™ to obtain a reworked calibration sheet containing the coefficients 'K_r' and 'K_j'. (Typically, K_r = 1.1 and K_j = 500). If you do not want to implement the above term, enter 0.0 for K_r.

5.4. Liquid Flow Rate for Provers

The calculations performed for unidirectional, bi-directional and small volume (compact) provers are as follows:

5.4.1. Prove Gross Flow Rate at Flowing Conditions (m³/hr)

Gross Flow Rate for Uni- and Bi-directional Provers 'PQ_{v(U/B)}'

$$PQ_{v(U/B)} = \frac{P_{fHz}}{K_{Fnom}} \times 3600$$

Gross Flow Rate for Small Volume (Compact) Provers 'PQ_{v(SVP)}'

$$PQ_{v(SVP)} = \frac{PV_b}{Td_{vol}} \times 3600$$

5.4.2. Nomenclature

PQ_{v(U/B)} = prove gross flow rate at flowing conditions for uni- and bi-directional provers, in cubic meters per hour (m³/hr)

PQ_{v(SVP)} = prove gross flow rate at flowing conditions for small volume (compact) provers, in cubic meters per hour (m³/hr)

PV_b = base prover volume at 15°C and equilibrium pressure, in cubic meters (m³)

P_{fHz} = total number of flow pulses per second during the prove

K_{Fnom} = nominal K factor, in pulses per barrel (f_{Hz}/m³) —supplied by the flow transmitter manufacturer

Td_{vol} = timer pulses accumulated between detectors switches (each pulse is 200 nanoseconds)

Td_{fmp} = timer pulses accumulated between first flow pulse after each detector switches (each pulse is 200 nanoseconds)

5.4.3. Meter Factors for Provers

Prove Meter Factor 'PM_F'

$$PM_F = \frac{PV_b \times C_{TSP} \times C_{PSP} \times C_{TLP} \times C_{PLP}}{\frac{Pf}{K_F} \times C_{TLM} \times C_{PLM}}$$

Where:

PM_F = prove meter factor (dimensionless)

PV_b = base prover volume

Pf = number of flow pulses during the prove

C_{TSP} = correction factor for effects of temperature on steel at the prover

For Uni- and Bi-directional Provers:

$$C_{TSP} = 1 + [(\bar{T} - \bar{T}_b) \times t_{coef}]$$

Where:

\bar{T} = average prover temperature, in °C

\bar{T}_b = average base prover temperature, in °C

t_{coef} = coefficient of cubical expansion per °C of the prover tube

For Small Volume (Compact) Provers:

$$C_{TSP} = \left(1 + [(\bar{T} - \bar{T}_b) \times t_{coef_P}] \right) \times \left(1 + [(\bar{T}_i - \bar{T}_b) \times t_{coef_i}] \right)$$

Where:

\bar{T} = average prover temperature, in °C

\bar{T}_i = average prover switch rod temperature, in °C

\bar{T}_b = average base prover temperature, in °C

t_{coef_P} = square coefficient of expansion per °C of the prover tube

t_{coef_i} = linear coefficient of cubical expansion per °C of the prover switch rod

C_{PSP} = correction factor for effects of pressure on steel at the prover

$$= 1 + \frac{(P - P_b) \times D}{E \times t}$$

Where:

P = internal prover pressure, in kPag

P_b = base prover pressure, in kPag

D = internal prover tube diameter, in mm

E = modulus of elasticity for prover tube

t = wall thickness of prover tube, in mm

C_{TLP} = correction factor for effects of temperature on liquid (volume correction factor) at the prover

= volume correction factor ' V_{CF} ', where the actual temperature ' T_a ' is replaced by the average temperature during the prove, at the prover (see **5.2.2** this chapter)

C_{PLP} = correction factor for effects of pressure on liquid at the prover

= correction factor for pressure on liquid ' C_{PL} ', where the flowing pressure ' P ' is replaced by average pressure during the prove, at the prover (see **5.2.3** this chapter)

C_{TLM} = correction factor for effects of temperature on liquid (volume correction factor) at the flowmeter

= volume correction factor ' V_{CF} ', where the actual temperature ' T_a ' is replaced by the average temperature during the prove, at the flowmeter (see **5.2.2** this chapter)

C_{PLM} = correction factor for effects of pressure on liquid at the flowmeter

= correction factor for pressure on liquid ' C_{PL} ', where the flowing pressure ' P ' is replaced by average pressure during the prove, at the flowmeter (see **5.2.3** this chapter)

Prove Meter Factor at Base Prove Flow Rate 'PM_{F_{PQ_b}}'

$$PM_{F_{PQ_b}} = PM_F + (M_{F_{BCPQ_b}} - M_{F_{BCPQ_v}})$$

Where:

$M_{F_{PQ_b}}$ = meter factor at base prove flow rate

PM_F = prove meter factor

$M_{F_{BCPQ_b}}$ = meter factor interpolated from base flowmeter factor curve, using base prove flow rate

$M_{F_{BCPQ_v}}$ = meter factor interpolated from base flowmeter factor curve, using actual prove flow rate

Meter Factor Offset from Base Curve Obtained from Proving 'M_{F_{PO}}'

$$M_{F_{PO}} = M_{F_{PQ_b}} - M_{F_{BCPQ_b}}$$

Where:

$M_{F_{PO}}$ = meter factor offset from base meter factor curve obtained from proving

$M_{F_{PQ_b}}$ = meter factor at base prove flow rate

$M_{F_{BCPQ_b}}$ = meter factor interpolated from base flowmeter factor curve, using base prove flow rate

5.5. Calculations for PID Control

5.5.1. Primary Variable Error % 'e_p'

Forward Action

$$e_p = \text{Primary Setpoint \% Span} - \text{Primary Variable \% Span}$$

Reverse Action

$$e_p = \text{Primary Variable \% Span} - \text{Primary Setpoint \%}$$

5.5.2. Secondary Variable Error % 'e_s'

Forward Action

$$e_s = \text{Secondary Gain} \times (\text{Sec. Setpoint \% Span} - \text{Sec. Variable \% Span})$$

Reverse Action

$$e_s = \text{Secondary Gain} \times (\text{Sec. Variable \% Span} - \text{Sec. Setpoint \% Span})$$

5.5.3. Control Output % 'C₀' (Before Startup Limit Function)

Controlling on Primary Variable

$$C_0 = \text{Primary Gain} \times (e_p + \sum e)$$

Controlling on Secondary Variable

$$C_0 = \text{Primary Gain} \times (e_s + \sum e)$$

5.5.4. Integral Error ' Σe '

Controlling on Primary Variable

$$\Sigma e = (\text{Repeats per Minute of Primary Variable} \times \text{Sample Period} \times e_p) + \Sigma e_{n-1}$$

Controlling on Secondary Variable

$$\Sigma e = (\text{Repeats per Minute of Sec Variable} \times \text{Sample period} \times e_s) + \Sigma e_{n-1}$$