

SST NEMA Enclosure Dimensions

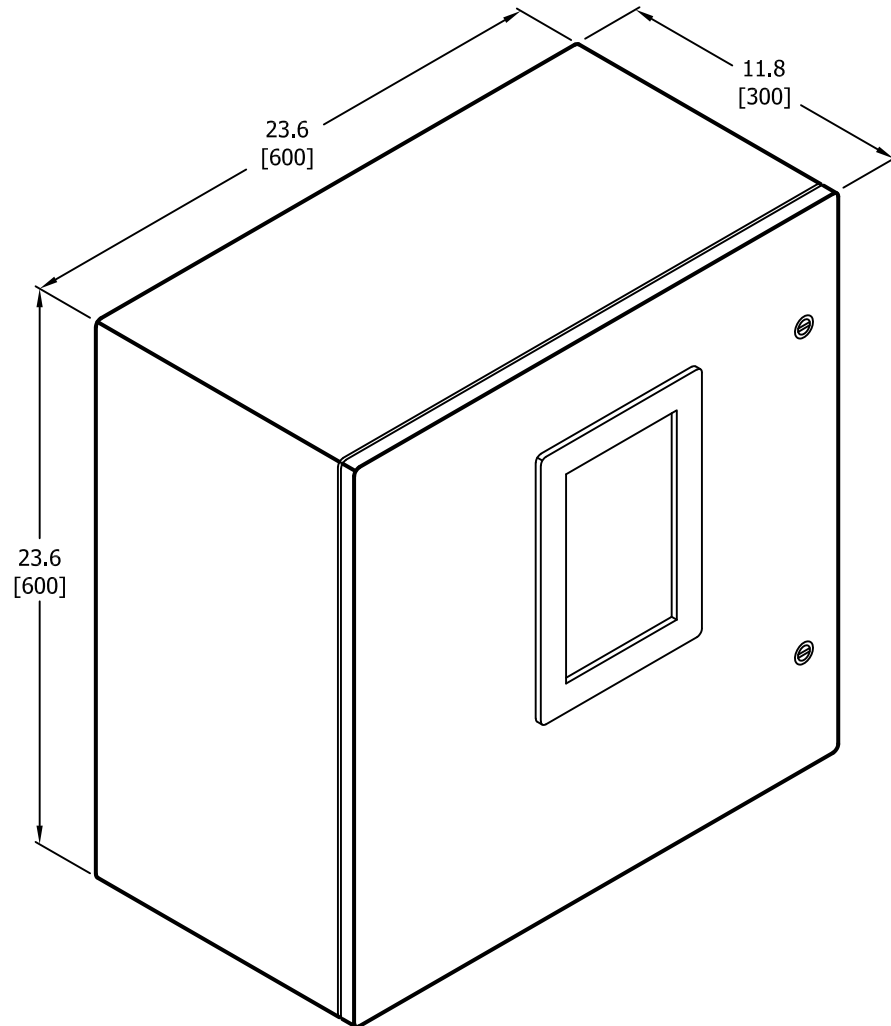

NOTES:

1. ESTIMATED UNIT WEIGHT:
SINGLE OMNI ~ 87 LBS. (39 KGS)
DUAL OMNI ~ 100 LBS. (45 KGS)
2. STAINLESS STEEL MOUNTING KIT INCLUDED
3. OPTIONAL OUTER DOOR LATCHES (STAINLESS STEEL):
H0300001 ~ THUMB TURN, PAD LOCKABLE
H0300002 ~ L-HANDLE, WITH OUT LOCK

DIMENSION NOTES:

1. DIMENSIONS FOR REFERENCE ONLY.
2. DIMENSIONS SHOWN IN INCHES AND [MILLIMETERS].



BACK

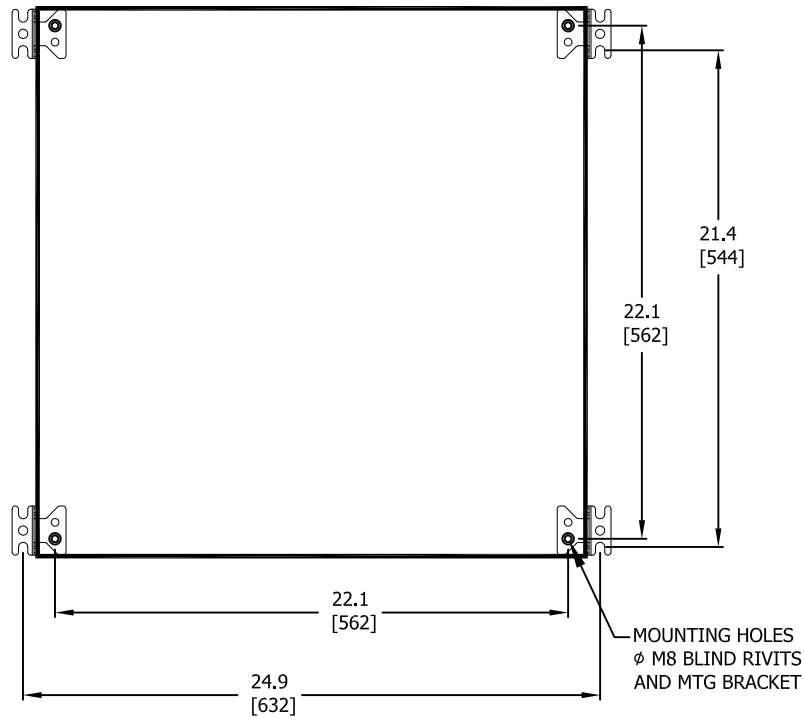

SIDE

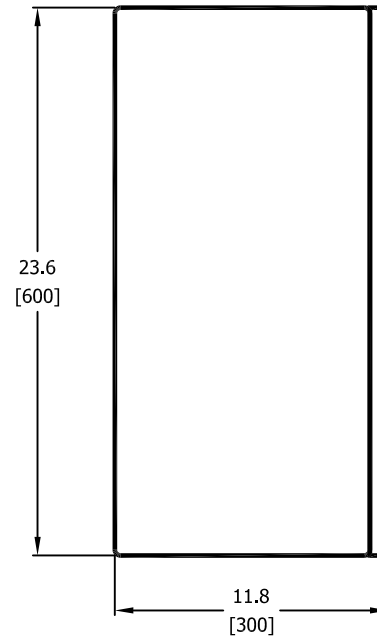

FRONT

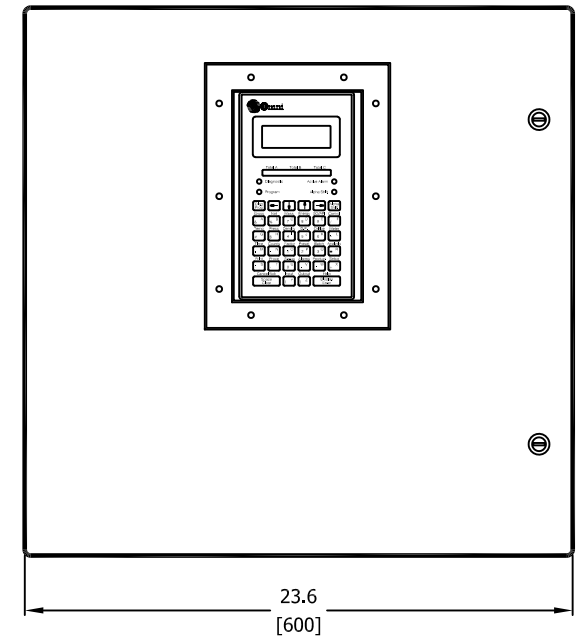

INSIDE

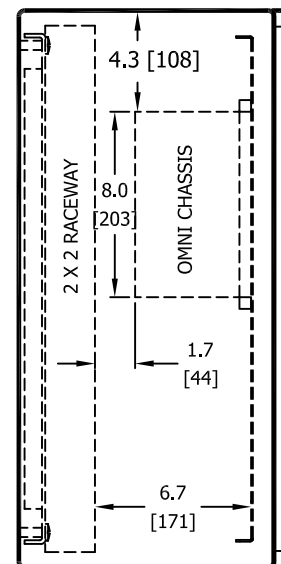

INTERNAL BACK PANEL

